

3020G

直接驱动式

程序电脑花式机

DIRECT DRIVE

PROGRAMMABLE ELECTRONIC PATTERN SEWER

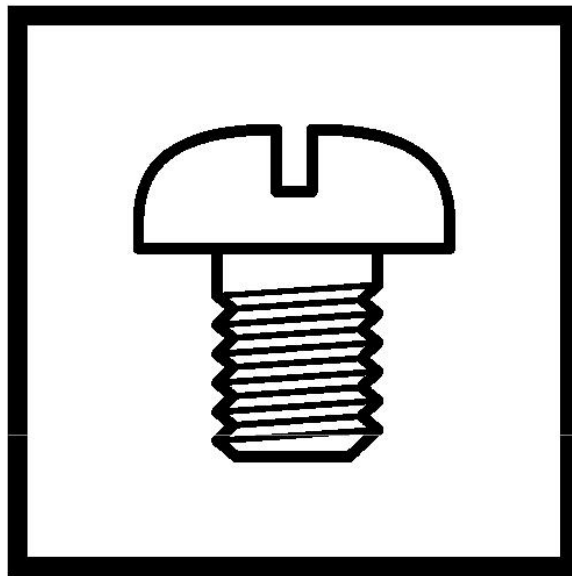

A1 . 机体部分 / Machine body

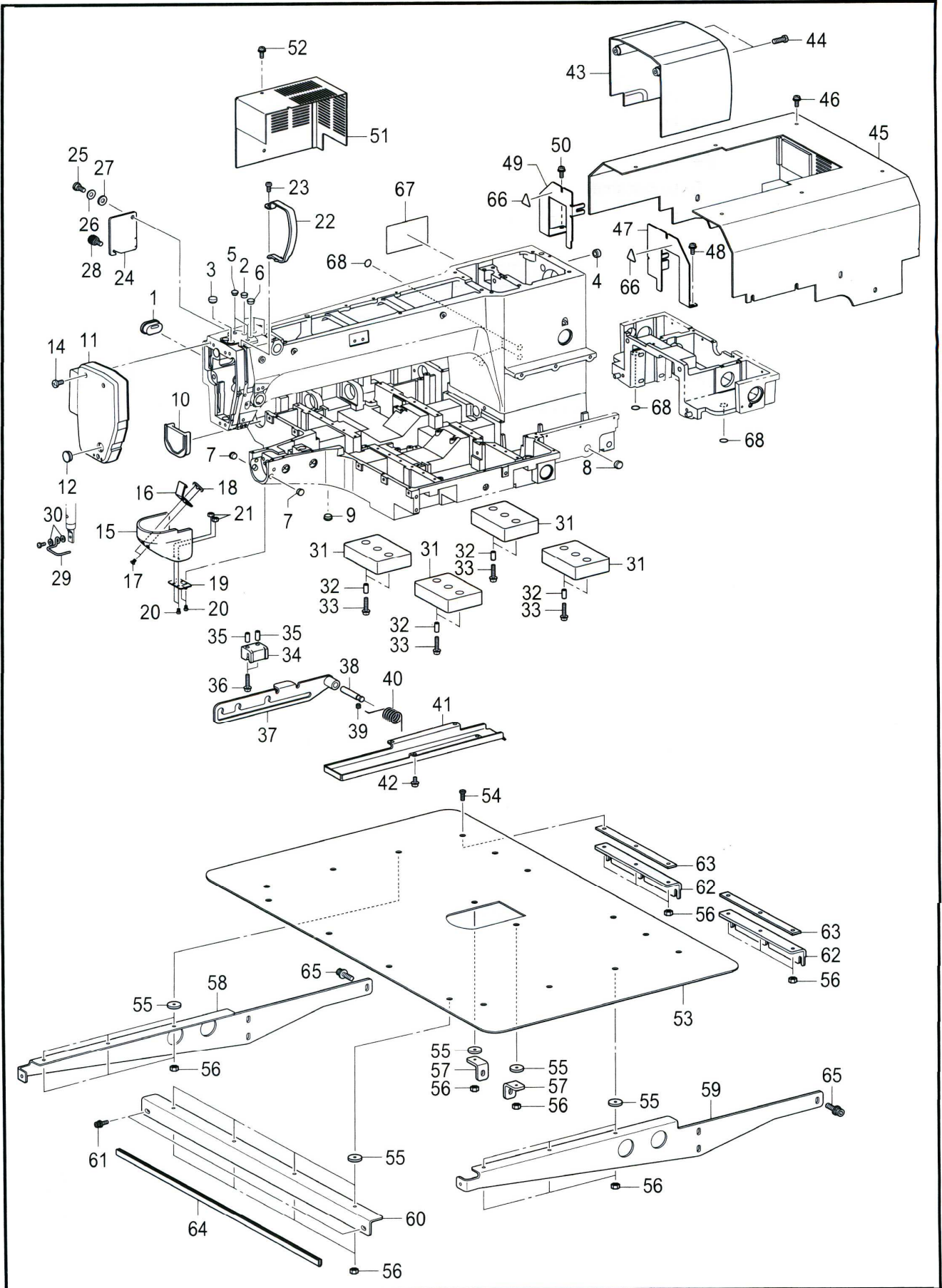

3020>A1. 机体部分/Machine body						
序号	ERP编号	零部件序号	数量	名称	NAME OF PARTS	备注
A1-01	PF1310A03	SA4596001	1	橡皮塞 20-15	RUBBER CAP 20-15	
A1-02	PF1310A05	104821001	3	橡皮塞 10.5	RUBBER CAP 10.5	
A1-03	PF1310A33	S20164001	1	橡皮塞 13	RUBBER CAP 13	
A1-04	PF1310A33	S20164001	1	橡皮塞 13	RUBBER CAP 13	
A1-05	PF99900109	104450101	4	橡皮塞 8	RUBBER CAP 8	
A1-06	PFHC0106	117936001	1	橡皮塞 9.4	RUBBER CAP 9.4	
A1-07	PF1310A40	S44010001	4	橡皮塞 11.5	RUBBER CAP 11.5	
A1-08	PFHC0108	150592001	3	橡皮塞 16	RUBBER CAP 16	
A1-09	PF1310A11	104449001	1	橡皮塞 15.5	RUBBER CAP 15.5	
A1-10	PFHC0110	SA8548101	1	底板盖	BED COVER	
A1-11	PF1310A10	SA4600001	1	面板	FACE PLATE	
A1-12	PF1310A11	104449001	1	橡皮塞 15.5	RUBBER CAP 15.5	
A1-14	PF8420M-D30846	062061016	3	螺钉 M6×10	SCREW PAN M6×10	
A1-15	PF1310A14	SA4603101	1	大旋梭盖	SHUTTLE RACE COVER	
A1-16	PF1310A15	SA6272001	1	大旋梭盖挂钩 D	SHUTTLE RACE COVER HOOK D	
A1-17	PF1310A16	004300513	2	螺钉 M3×5	SCREW, PAN M3×5	
A1-18	PF1310A17	SA3264001	1	板螺母	NUT PLATE	
A1-19	PF1310A18	SA6207001	1	铰链	HINGE	
A1-20	PF1310A38	062300506	4	螺钉 M3×5	SCREW, PAN M3×5	
A1-21	PF1900A0524	021300103	2	螺母 M3	NUT M3	
A1-22	PF1310A23	SA3200101	1	挑线杆防护罩	THREAD TAKE-UP COVER	
A1-23	PF1310A24	062401006	1	螺钉 M4×10	SCREW PAN M4×10	
A1-24	PF1310A25	SA4604001	1	间歇盖板	STEPPING COVER	
A1-25	PF1310A26	SA3306001	1	段螺钉 7-3	SHOULDER SCREW, 7-3	
A1-26	PF1310A27	120265002	1	弹簧垫圈	SPRING WASHER	
A1-27	PF1310A28	S07350002	1	垫圈	WASHER PLAIN	
A1-28	PF1310A29	S36475000	1	螺钉 M5	WASHER M5	
A1-29	PFHC0129	SA8679001	1	护指器	FINGER GUARD	
A1-30	PF1310A35	025350332	2	平垫圈 L3.5	WASHER PLAIN L3.5	
A1-31	PFHC0131	SA8670001	4	防震垫	CUSHION	
A1-32	PFHC0132	SA8680001	8	管套	SPACER	
A1-33	PF1900A0781	0A5402005	8	螺栓M4×20DB	SCREW PAN (S/P WASHER) M4×20	
A1-34	PFHC0134	SA8880001	1	防震橡皮垫	RUBBER CUSHION	
A1-35	PFHC0132	SA8680001	2	管套	SPACER	
A1-36	PF1900A0781	0A5402005	2	螺栓M4×20DB	SCREW PAN (S/P WASHER) M4×20	
A1-37	PFHC0137	SA8549001	1	头部支撑杆	SUPPORT LEVER	
A1-38	PFHC0138	SA8550001	1	头部支撑杆轴	SUPPORT LEVER SHAFT	
A1-39	PF1310B24	012060636	1	螺钉M6×6	SET SCREW SOCKET (FT) M6×6	
A1-40	PFHC0140	SA8551001	1	弹簧	TOSHON SPRING	
A1-41	PFHC0141	SA8552001	1	供油盘	OIL PAN	
A1-42	PF1310C233	0A5401006	4	螺栓(带垫圈) M4×10DB	SCREW PAN (S/P WASHER) M4×10	
A1-43	PFHC0143	SA8553001	1	马达罩	MOTOR COVER	
A1-44	PF8420M-D30846	062061616	2	螺钉 M6×16	SCREW PAN M6×16	
A1-45	PFHC0145	SA8816001	1	后盖组件	REAR COVER ASSY	
A1-46	PF1310C233	0A5401006	16	螺栓(带垫圈) M4×10DB	SCREW PAN (S/P WASHER) M4×10	
A1-47	PFHC0147	SA8555001	1	后盖 FR	REAR COVER	
A1-48	PF1310C233	0A5401006	3	螺栓(带垫圈) M4×10DB	SCREW PAN (S/P WASHER) M4×10	
A1-49	PFHC0149	SA8556001	1	后盖 FL	REAR COVER	
A1-50	PF1310C233	0A5401006	3	螺栓(带垫圈) M4×10DB	SCREW PAN (S/P WASHER) M4×10	
A1-51	PFHC0151	SA8557001	1	马达盖(X)	X MOTOR COVER	
A1-52	PF1310C233	0A5401006	4	螺栓(带垫圈) M4×10DB	SCREW PAN (S/P WASHER) M4×10	
A1-53	PFHC0153	SA8559001	1	针板补助板	AUXILIARY PLATE	
A1-54	PF1310C236	SA8560001	18	螺钉 M4×12	SCREW M4×12	
A1-55	PF1310C235	SA4677101	12	补助板缓冲	AUXILIARY PLATE CUSHION	
A1-56	PF1310L06	021400206	18	六角螺母 M4	NUT 2 M4	
A1-57	PF1310C238	SA4676101	2	补助板支架	AUXILIARY PLATE BRACKET	
A1-58	PFHC0158	SA8561001	1	补助板支架 L	AUXILIARY PLATE BRACKET L	

A1 . 机体部分 / Machine body

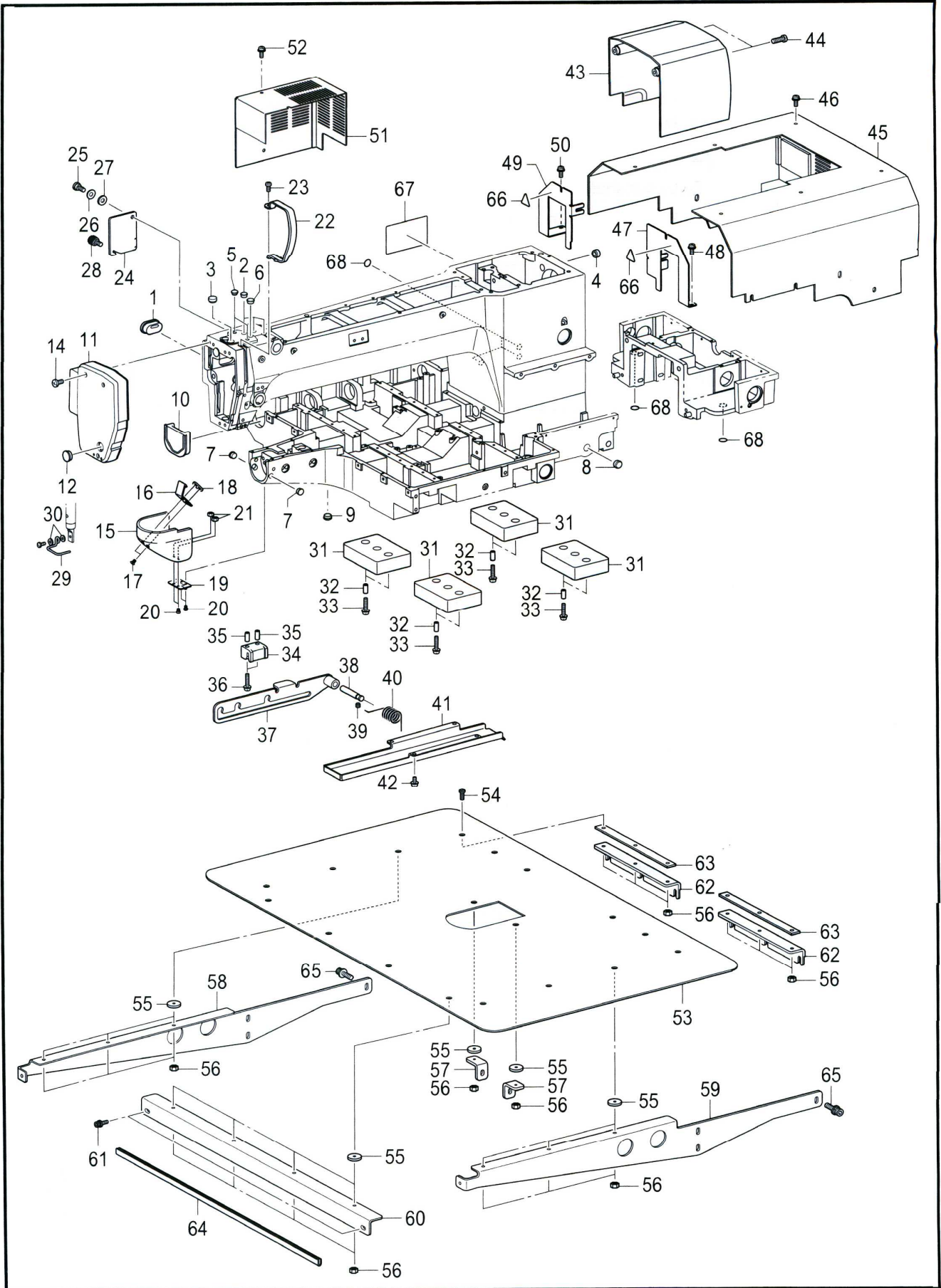

3020>A1. 机体部分/Machine body						
序号	ERP编号	零部件序号	数量	名称	NAME OF PARTS	备注
A1-59	PFHC0159	SA8562001	1	补助板支架 R	AUXILIARY PLATE BRACKET R	
A1-60	PFHC0160	SA8563001	1	补助板支架 M	AUXILIARY PLATE BRACKET M	
A1-61	PF9820E12	S55481001	2	螺栓 (带垫圈) M4×12	BOLT SOCKET(S/P WASHER)M4×12	
A1-62	PFHC0162	SA8564001	2	补助板支架 B	AUXILIARY PLATE BRACKET B	
A1-63	PFHC0163	SA8672001	2	补助板防震垫 B	AUXILIARY PLATE CUSHION B	
A1-64	PFHC0164	SA8879001	1	调整长条 L=540	TRIMS L=540	
A1-65	PF1310A37	S42446001	14	螺栓 M6×14(三合一)	BOLT SOCKET(S/P WASHER)M6×14	

3020>A2. 机体部分/Machine body						
序号	ERP编号	零部件序号	数量	名称	NAME OF PARTS	备注
A2-01	PFHC0201	SA8668001	2	头部铰链轴	HINGE SHAFT	
A2-02	PF1310B24	012060636	2	螺钉M6×6	SET SCREW SOCKET (FT) M6×6	
A2-03	PFHC0203	SA8665001	1	油盘组件	OIL PAN ASSY	
A2-04	SCJ2095	032361306	4	木螺钉 M3.5×13	WOOD SCREW ROUND 2 M3.5×13	
A2-05	PFHC0205	SA8667001	2	橡皮轴套	RUBBER BUSH	
A2-06	PFHC0206	SA8669001	2	铰链轴支架	HINGE HOLDER	
A2-07	PFHC0207	018087036	4	螺栓 M8×65	BOLT SOCKET M8×70	
A2-08	SCJ3024	028080246	4	弹簧垫圈 2-8	WASHER SPRING 2-8	
A2-09	PF1310R103	213650001	4	垫圈 2.3×8.5×38	WASHER 2.3×8.5×38ST	
A2-10	PFHC0138	SA8550001	1	头部支撑杆轴	SUPPORT LEVER SHAFT	
A2-11	PF1310B24	012060636	2	螺钉M6×6	SET SCREW SOCKET (FT) M6×6	
A2-12	PFHC0212	SA8671001	1	头部支撑座	SUPPORT LEVER BASE	
A2-13	PFHC0207	018087306	2	螺栓 M8×65	BOLT SOCKET M8×70	
A2-14	SCJ3024	028080246	2	弹簧垫圈 2-8	WASHER SPRING 2-8	
A2-15	PF1310R103	213650001	2	垫圈 2.3×8.5×38	WASHER 2.3×8.5×38ST	
A2-16	PFHC0216	SA8673001	1	减震器支撑 L	HOLDER ABSORBER L	
A2-17	PFHC0217	SA8674001	1	减震器支撑 R	HOLDER ABSORBER R	
A2-18	PF1310R102	SA3387001	4	螺栓 M6×75	BOLT SOCKET M6×75	
A2-19	PF1310R103	213650001	4	垫圈 2.3×8.5×38	WASHER 2.3×8.5×38ST	
A2-20	SCJ3005	028060246	4	弹簧垫圈 2-6	WASHER SPRING 2-6	
A2-21	PF1310D141	021060106	4	螺母 M6	NUT 1 M6	
A2-22	PF1310R109	SA5251001	1	垫圈	SPACER	
A2-23	PF1310R110	018064031	1	螺栓 M6×40	BOLT SOCKET M6×40	
A2-24	PF19000120	021060106	1	螺母 M6	NUT 1 M6	
A2-25	PF1310R112	SA4847001	1	轴 U	SHAFT U	
A2-26	PF1310B24	012060636	2	螺钉M6×6	SET SCREW SOCKET (FT) M6×6	
A2-27	PF1310R114	S17974101	1	轴D	SHAFT D	
A2-28	PF1310R115	S17975100	2	轴套 GS	SHAFT COLLAR, GAS	
A2-29	PF1310R116	025080132	2	垫圈 S8	WASHER PLAIN S8	
A2-30	PF1310R117	048060342	2	垫圈 E6	RETAINING RING E6	
A2-31	PFHC0231	SA8675001	1	减震器	SHOCK ABSORBER GAS	
A2-32	PF1310R09	114486001	1	油壶	OILER	

B. 上轴 · 针杆装置 / Upper shaft and needle bar mechanism

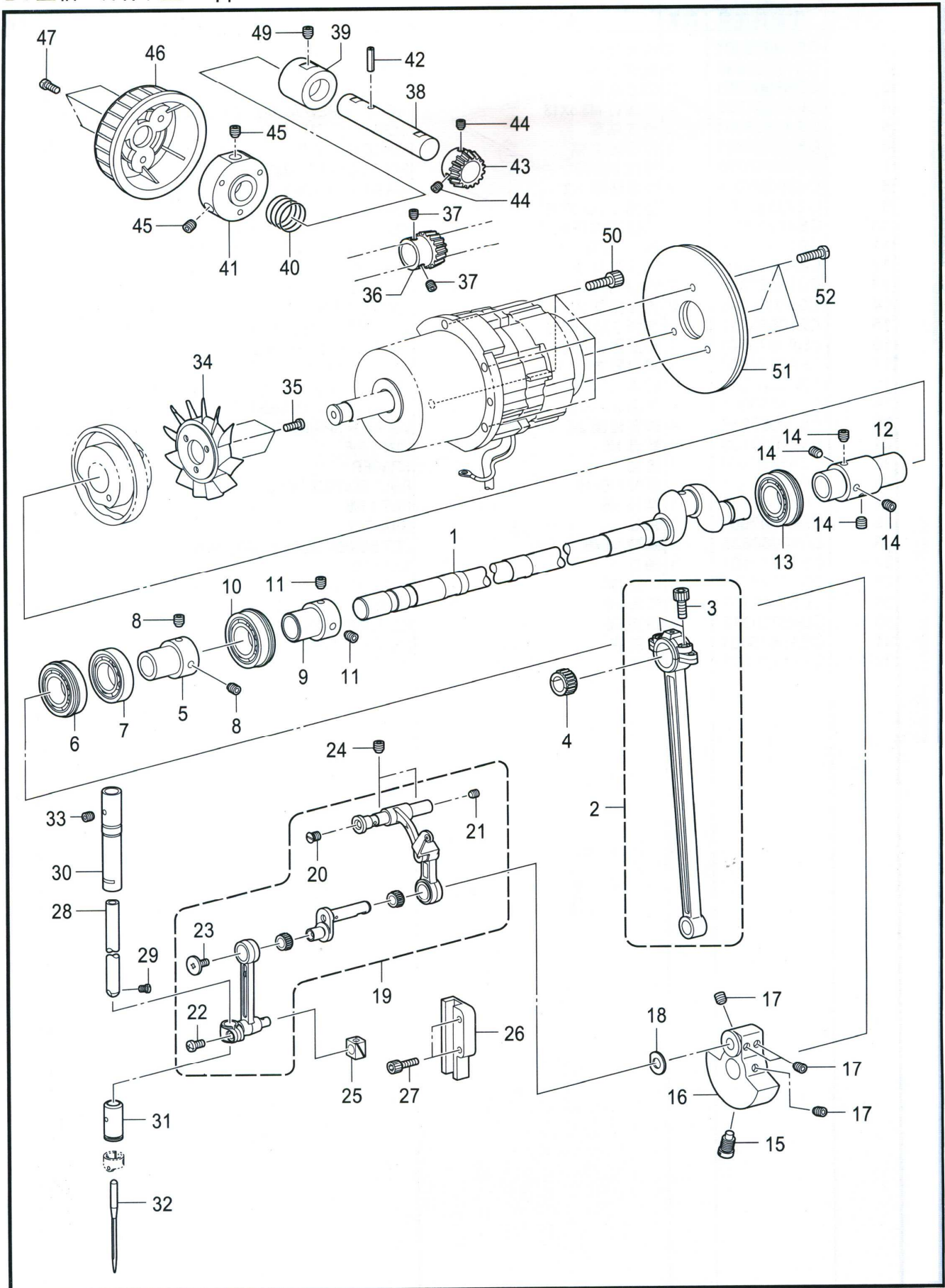

3020>B. 上轴·针杆装置/Upper shaft and needle bar mechanism						
序号	ERP编号	零部件序号	数量	名称	NAME OF PARTS	备注
B-01	PFHC0301	SA8565101	1	上轴	UPPER SHAFT	
B-02	PF1310B02	SA3499001	1	曲柄轴组件	CRANK ROD ASSY	
B-03	PF1310B03	018501636	2	螺栓 M5×16	BOLT SOCKET M5×16	
B-04	PF1310B04	SA4172001	1	滚针轴承	NEEDLE BEARING:BULE	
B-05	PF1310B05	SA3206001	1	轴承套		
B-06	PF1310B06	SA4179001	1	轴承 6904DDUNR		
B-07	PF1310B07	SA4180001	1	轴承 R-6904DDU	BALL BEARING 6904DDU	
B-08	SCJ2033	S23651001	2	固定螺钉 M6×6	SET SCREW SOCKET (FT)M6×6	
B-09	PF1310B05	SA3206001	1	轴承套	BALL BEARING BUSH	
B-10	PF1310B10	SA4177001	1	轴承 6004DDUNR	BALL BEARING 6004DDUNR	
B-11	SCJ2033	S23651001	2	固定螺钉 M6×6	SET SCREW SOCKET (FT)M6×6	
B-12	PF1310B12	SA4608101	1	管接头 G	JOINT G	
B-13	PF1310B13	SA4178001	1	轴承 6204DDUNR	BALL BEARING 6204DDUNR	
B-14	SCJ2033	S23651001	4	固定螺钉 M6×6	SET SCREW SOCKET (FT)M6×6	
B-15	PF1310B15	S25235001	1	螺钉 M8	SCREW M8	
B-16	PF1310B16	SA4609101	1	曲柄 G	THREAD TAKE-UP CRANK G	
B-17	SCJ2033	S23651001	4	固定螺钉 M6×6	SET SCREW SOCKET (FT)M6×6	
B-18	PF1310B18	110367001	1	垫圈 8	WASHER, PLAIN SPECIAL 8	
B-19	PF1310B19	SA6182001	1	针杆连杆组件 FK	THREAD TAKE-UP LEVER FK SET	
B-20	PF1310B20	SA2958001	1	螺钉 M5×6	SCREW FLAT M5×6	
B-21	BF310164514	012500536	1	螺钉 M5×5	SET SCREW SOCKET (FT)M5×5	
B-22	PF1310B22	062400816	1	螺钉 M4×8	SCREW PAN M4×8	
B-23	PF1310B23	145465001	1	螺钉 SM3. 57-40×6L	SCREW SM3. 57-40×6L	
B-24	PF1310B24	012060636	2	螺钉M6×6	SET SCREW SOCKET (FT) M6×6	
B-25	PF1310B25	142211001	1	滑块	SLIDE BLOCK	
B-26	PF1310B26	SA3528001	1	滑块导向 B	SLIDE BLOCK GUIDE	
B-27	PF1310B27	018401636	2	螺栓 M4×16	BOLT SOCKET M4×16	
B-28	PF1310B28	SA4622001	1	针杆	NEEDLE BAR	
B-29	PF1310B29	144458001	1	螺钉 SM3. 57-40×4.5	SET SCREW SM3. 57-40×4.5	
B-30	PF1310B30	SA4666001	1	针杆轴套 UK	NEEDLE BAR BUSH UK	
B-31	PF1310B31	SA3224001	1	针杆轴套 D	NEEDLE BAR BUSH D	
B-32	PFDTDP1719	145646019	1	机针 DP×17	NEEDLE DP×17	
B-33	PF1310B52	012060536	1	螺钉 M6×5	SET SCREW SOCKET (FT) M6×5	
B-34	PF1310B33	S38713100	1	叶轮	FAN	
B-35	PF1310C233	062400816	3	螺钉 M4×8(三合一)	SCREW PAN M4×8	
B-36	PF1310B35	SA6108001	1	齿轮 R	PULLEY GEAR R	
B-37	BF310164514	012500536	2	螺钉 M5×5	SET SCREW SOCKET (FT)M5×5	
B-38	PF1310B37	SA4626101	1	上轮轴	PULLEY SHUFT	
B-39	PF1310B38	SA4627001	1	上轮轴套	PULLEY BUSH	
B-40	PF1310B39	SA4628101	1	上轮弹簧	PULLEY SPRING	
B-41	PF1310B40	SA4629001	1	上轮基座	PULLEY BASE	
B-42	PF1310B41	047401242	1	弹簧销 4×12	PIN SPRING ROLL AW4	
B-43	PF1310B42	SA4624001	1	齿轮	PULLEY GEAR L	
B-44	BF310164514	012500536	2	螺钉 M5×5	SET SCREW SOCKET (FT)M5×5	
B-45	SCJ2033	S23651001	2	固定螺钉 M6×6	SET SCREW SOCKET (FT)M6×6	
B-46	PF1310B45	SA4630001	1	上轮	PULLEY	
B-47	PF1310C233	062401006	3	螺钉 M4×8(三合一)	SCREW PAN M4×10	
B-49	PF1310B24	012060636	1	螺钉M6×6	SET SCREW SOCKET (FT) M6×6	
B-50	PF1310B03	018501636	4	螺栓 M5×16	BOLT SOCKET M5×16	
B-51	PF1310B50	SA5230001	2	惯性轮 2	FRIES WHEEL 2	
B-52	PF1310C233	062401016	3	螺钉 M4×8(三合一)	SCREW PAN M4×10	

C1 . 送料装置 / Feed mechanism

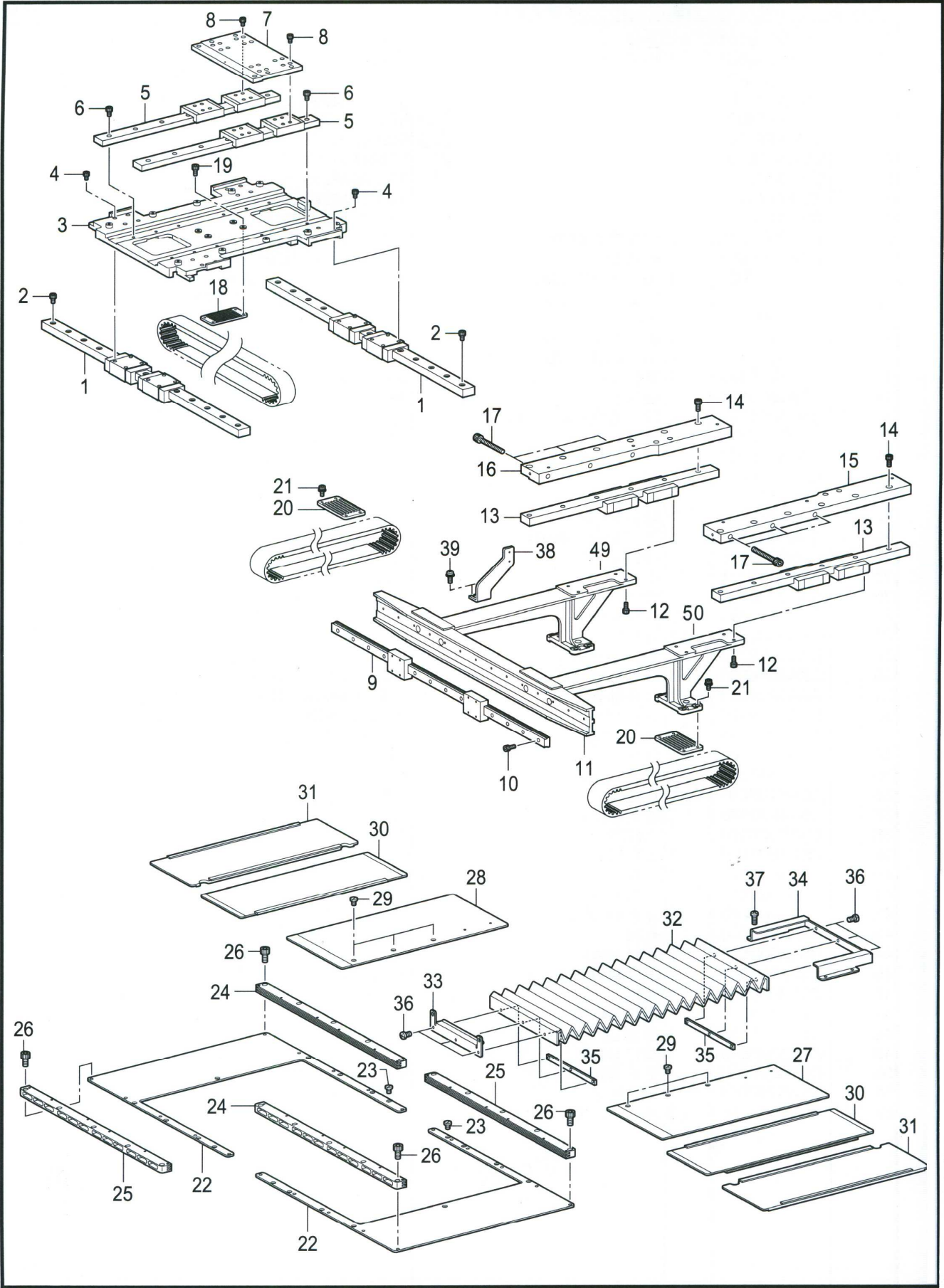

3020>C1. 送料装置/Feed mechanism						
序号	ERP编号	零部件序号	数量	名称	NAME OF PARTS	备注
C1-01	PFHC0401	SA8566001	2	X-LM导向 F (560)	X-LM GUIDE F	
C1-02	PF1310C110	018400836	22	螺栓 M4×8	BOLT SOCKET M4×8	
C1-03	PFHC0403	SA8567001	1	基板 (X)	BASE PLATE X	
C1-04	PFHC0404	018300536	16	螺栓 M3×5	BOLT SOCKET M3×5	
C1-05	PFHC0405	SA8568001	2	Y-LM导向 F (310)	Y-LM GUIDE F	
C1-06	PF1310C110	018400836	12	螺栓 M4×8	BOLT SOCKET M4×8	
C1-07	PFHC0407	SA8569101	1	基板组件(Y)	BASE PLATE Y ASSY	
C1-08	PFHC0404	018300536	16	螺栓 M3×5	BOLT SOCKET M3×5	
C1-09	PFHC0409	SA8571001	1	X-LM导向 R (550)	X-LM GUIDE R	
C1-10	PF9820D26	018301036	14	螺栓 M3×12	BOLT SOCKET M3×10	
C1-11	PFHC0411	SA8819001	1	Y臂组件	Y-ARM ASSY	
C1-12	PF9820E12	018401236	8	螺栓 M4×12	BOLT SOCKET M4×12	
C1-13	PFHC0413	SA8574001	2	Y-LM导向 R (336)	Y-LM GUIDE R	
C1-14	PF1310J48	018501236	12	螺栓 M5×12	BOLT SOCKET M5×12	
C1-15	PFHC0415	SA8575001	1	Y-导向支座 R	Y-LM GUIDE BRACKET R	
C1-16	PFHC0416	SA8576001	1	Y-导向支座 L	Y-LM GUIDE BRACKET L	
C1-17	PF1310R102	018066036	6	螺栓 M6×60	BOLT SOCKET M6×60	
C1-18	PFHC0418	SA8590001	1	皮带支撑板	BELT HOLDER	
C1-19	PF9820E12	018401036	4	螺栓 (带垫圈) M4×12	BOLT SOCKET M4×10	
C1-20	PFHC0418	SA8590001	2	皮带支撑板	BELT HOLDER	
C1-21	PF9820E12	S55481001	8	螺栓 (带垫圈) M4×12	BOLT SOCKET(S/P WASHER)M4×12	
C1-22	PFHC0422	SA8608001	2	固定盖	FIXTION	
C1-23	PF1310J69	SA3538001	14	螺钉 M4×8	SCREW M4×8	
C1-24	PFHC0424	SA8609001	2	盖轨组件 FR	COVER RAIL FR ASSY	
C1-25	PFHC0425	SA8611001	2	盖轨组件 FL	COVER RAIL FL ASSY	
C1-26	PF1310C252	018401036	20	螺栓 M4×10	BOLT SOCKET M4×10	
C1-27	PFHC0427	SA8612001	1	内盖组件 R	INSIDE COVER R ASSY	
C1-28	PFHC0428	SA8615001	1	内盖组件 L	INSIDE COVER L ASSY	
C1-29	PF1310J69	SA3538001	6	螺钉 M4×8	SCREW M4×8	
C1-30	PFHC0430	SA8617001	2	中盖组件	MIDDLE COVER ASSY	
C1-31	PFHC0431	SA8619001	2	外盖组件	OUTSIDE COVER ASSY	
C1-32	PFHC0432	SA8622001	1	波纹片	BELLOW	
C1-33	PFHC0433	SA8623001	1	波纹片支座 F	BELLOW PRESSER F	
C1-34	PFHC0434	SA8624001	1	波纹片支座 R	BELLOW PRESSER R	
C1-35	PFHC0435	SA8625001	2	波纹片螺母	BELLOW NUT	
C1-36	PF1310C248	062300416	6	螺钉 M3×4	SCREW PAN M3×4	
C1-37	PF1310A24	062401016	4	螺钉 M4×10	SCREW PAN M4×10	
C1-38	PFHC0438	SA8626001	1	Y感应器安装板	SENSOR PLATE Y	
C1-39	PF1310C233	0A5401006	2	螺栓 (带垫圈) M4×10DB	SCREW PAN(S/P WASHER)M4×10	
C1-49	PFHC0449		1	Y臂左架		
C1-50	PFHC0450		1	Y臂右架		

C2 . 送料装置 / Feed mechanism

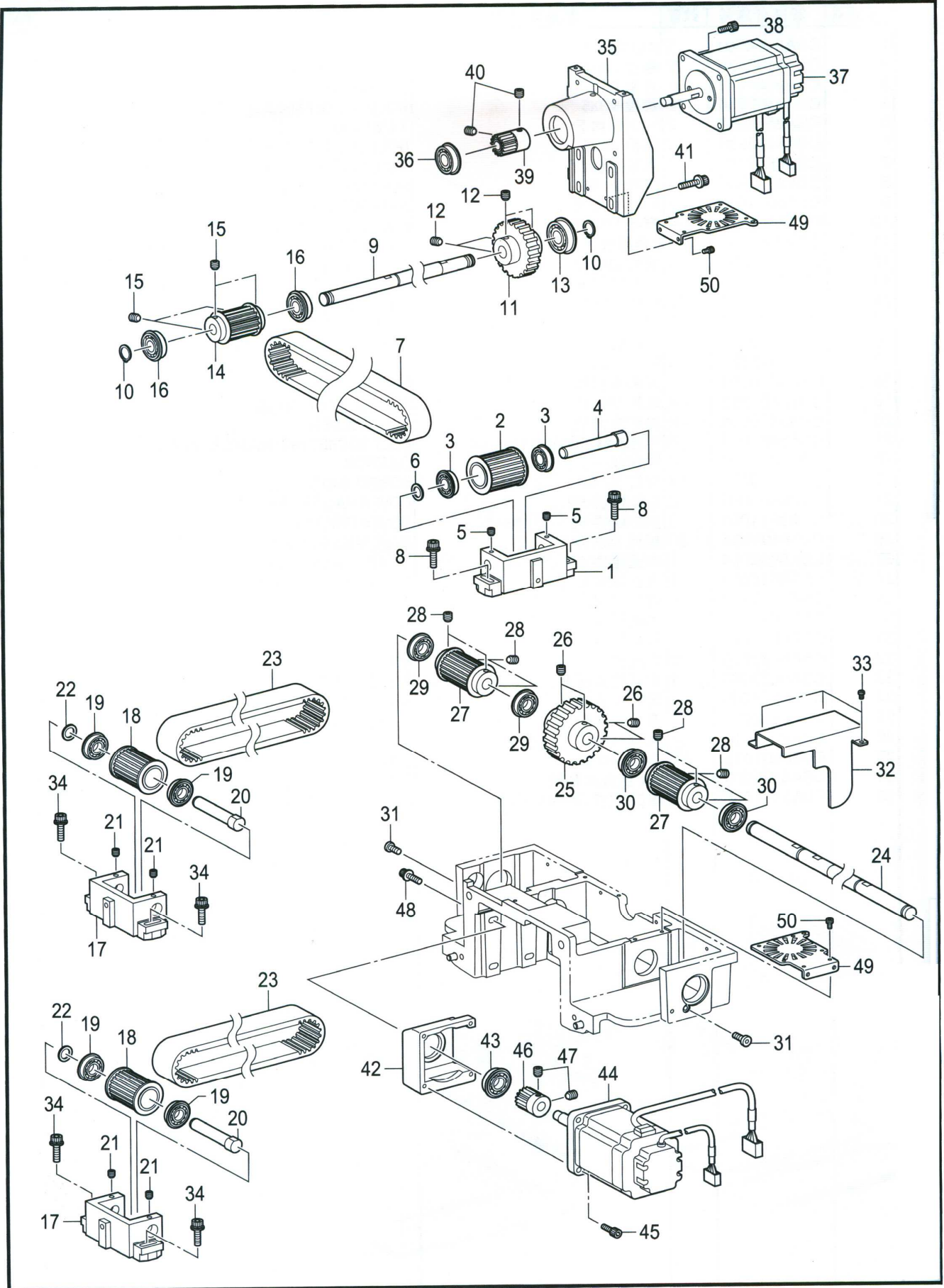

3020>C2. 送料装置/Feed mechanism						
序号	ERP编号	零部件序号	数量	名称	NAME OF PARTS	备注
C2-01	PFHC0501	SA8578001	1	X带轮基座	X-PULLEY BRACKET	
C2-02	PFHC0502	SA8579001	1	带轮组件A	PULLEY A ASSY	
C2-03	PFHC0503	SA1283001	2	球轴承 6901ZZNR	BALL BEARING 6901ZZNR	
C2-04	PFHC0504	SA8582001	1	带轮支点轴	PULLEY FULCRUM SHAFT	
C2-05	BF310164514	012500536	2	螺钉 M5×5	SET SCREW SOCKET(FT)M5×5	
C2-06	PFHC0506	SA8583001	1	支点轴套	PULLEY FULCRUM SHAFT COLLAR	
C2-07	PFHC0507	SA8584001	1	X-GT 皮带	X-GT BELT	
C2-08	PF430GC06	S47270001	5	螺栓 (带垫圈) M6×30	BOLT SOCKET(S/P WASHER)M6×30	
C2-09	PFHC0509	SA8585001	1	X驱动轴	DRIVE SHAFT X	
C2-10	SCJ1019	048150142	2	轴用挡圈 C15	RETAINING RING EXTERNAL C15	
C2-11	PFHC0511	SA8586001	1	X齿轮	GEAR X	
C2-12	PF1310B24	012060636	4	螺钉 M6×6	SET SCREW SOCKET(FT)M6×6	
C2-13	PF9820C27	SA6674001	1	轴承 6002ZZNR	BALL BEARING 6002ZZNR	
C2-14	PFHC0514	SA8587001	1	带轮组件 B	PULLEY B ASSY	
C2-15	PF1310B24	012060636	4	螺钉 M6×6	SET SCREW SOCKET(FT)M6×6	
C2-16	PFHC0516	076202850	2	R轴承 6202ZZNR	BALL BEARING RADIAL 6202ZZNR	
C2-17	PFHC0517	SA8592001	2	Y带轮基座	Y-PULLEY BRACKET	
C2-18	PFHC0502	SA8579001	2	带轮组件 A	PULLEY A ASSY	
C2-19	PFHC0503	SA1283001	4	球轴承 6901ZZNR	BALL BEARING 6901ZZNR	
C2-20	PFHC0504	SA8582001	2	带轮支点轴	PULLEY FULCRUM SHAFT	
C2-21	BF310164514	012500536	4	螺钉 M5×5	SET SCREW SOCKET(FT)M5×5	
C2-22	PFHC0506	SA8583001	2	支点轴套	PULLEY FULCRUM SHAFT COLLAR	
C2-23	PFHC0523	SA8593001	2	Y-GT皮带	Y-GT BELT	
C2-24	PFHC0524	SA8595001	1	Y驱动轴	DRIVE SHAFT Y	
C2-25	PFHC0525	SA8596001	1	Y齿轮	GEAR Y	
C2-26	PF1310B24	012060636	4	螺钉 M6×6	SET SCREW SOCKET(FT)M6×6	
C2-27	PFHC0514	SA8587001	2	带轮组件 B	PULLEY B ASSY	
C2-28	PF1310B24	012060636	8	螺钉 M6×6	SET SCREW SOCKET(FT)M6×6	
C2-29	PF9820C27	SA6674001	2	轴承 6002ZZNR	BALL BEARING 6002ZZNR	
C2-30	PFHC0516	076202850	2	R轴承 6202ZZNR	BALL BEARING RADIAL 6202ZZNR	
C2-31	PFHC0531	SA8597001	2	螺栓 M5×12	BOLT SOCKET M5×12	
C2-32	PFHC0532	SA8602001	1	Y齿轮罩	COVER GEAR Y	
C2-33	PF1310C233	062400816	3	螺钉 M4×8(三合一)	SCREW PAN M4×8	
C2-34	PF430GC06	S47270001	4	螺栓 (带垫圈) M6×30	BOLT SOCKET(S/P WASHER)M6×30	
C2-35	PFHC0535	SA8604001	1	X马达基座	MOTOR BRACKET X	
C2-36	PFHC0536	SA8599001	1	轴承 6201ZZNR	BALL BEARING 6201ZZNR	
C2-37	PFHC0537	SA8538001	1	脉冲马达组件 X	PULSE MOTOR ASSY X	
C2-38	PF1900A0256	018501636	4	螺栓 M5×16	BOLT SOCKET M5×16	
C2-39	PFHC0539	SA8607001	1	X马达齿轮	MOTOR GEAR X	
C2-40	PF1310B24	012060636	2	螺钉 M6×6	SET SCREW SOCKET(FT)M6×6	
C2-41	PF430GC06	S47270001	4	螺栓 (带垫圈) M6×30	BOLT SOCKET(S/P WASHER)M6×30	
C2-42	PFHC0542	SA8598001	1	Y马达基座	MOTOR BRACKET Y	
C2-43	PFHC0536	SA8599001	1	轴承 6201ZZNR	BALL BEARING 6201ZZNR	
C2-44	PFHC0544	SA8542001	1	脉冲马达组件 Y	PULSE MOTOR ASSY Y	
C2-45	PF1900A0256	018501636	4	螺栓 M5×16	BOLT SOCKET M5×16	
C2-46	PFHC0546	SA8601001	1	Y马达齿轮	MOTOR GEAR Y	
C2-47	PF1310B24	012060636	2	螺钉 M6×6	SET SCREW SOCKET(FT)M6×6	
C2-48	PF430GC06	S47269001	4	螺栓 (带垫圈) M6×20	BOLT SOCKET(S/P WASHER)M6×20	
C2-49	PFHC0549	SA8694001	2	风扇安装板	FAN BRACKET	
C2-50	PF1310C233	018400836	4	螺钉 M4×8(三合一)	BOLT SOCKET M4×8	

C3 . 送料装置 / Feed mechanism

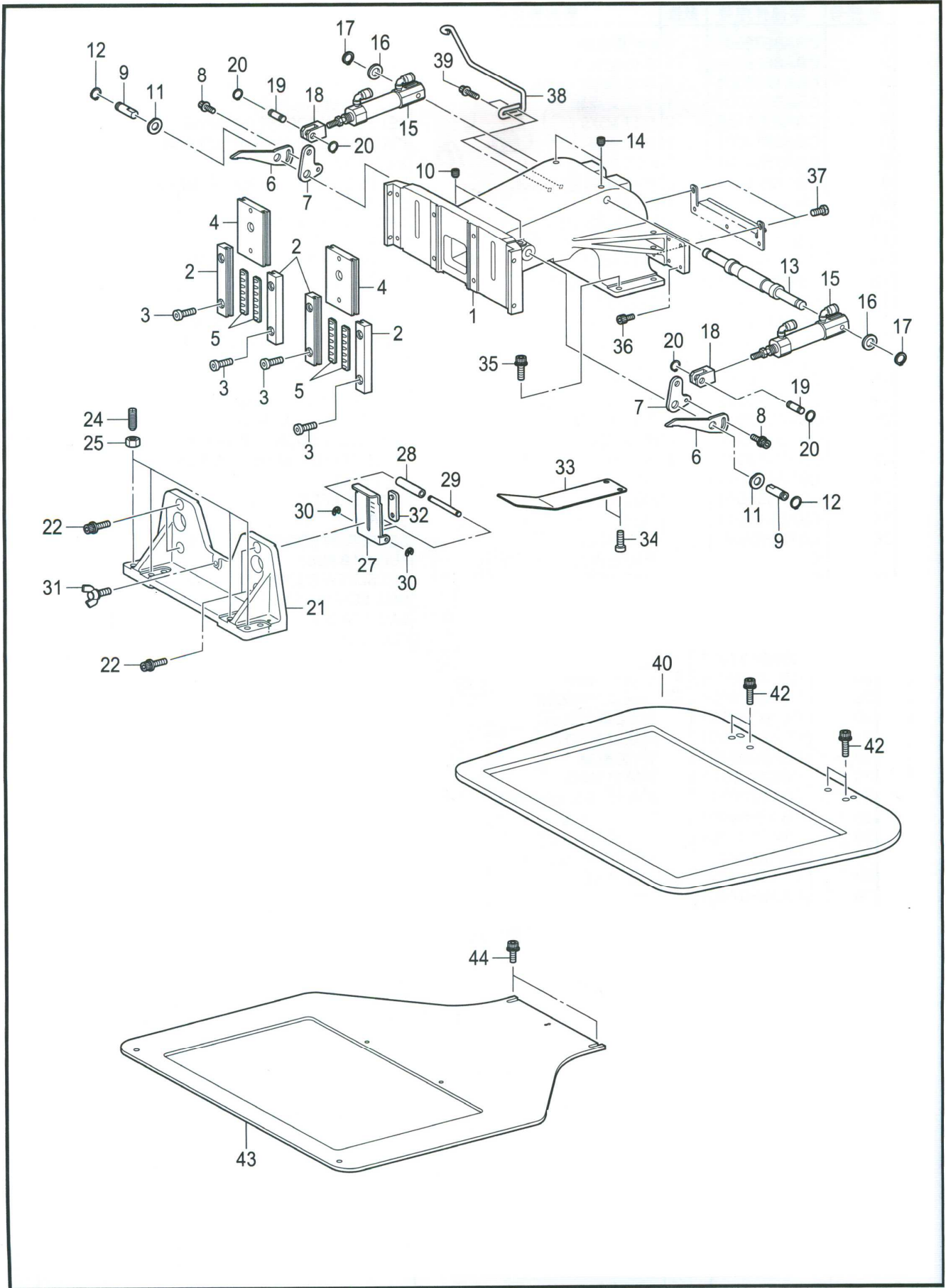

3020>C3. 送料装置/Feed mechainsm						
序号	ERP编号	零部件序号	数量	名称	NAME OF PARTS	备注
C3-01	PFHC0601	SA8628001	1	抬压臂	WORK CLAMP ARM	
C3-02	PFHC0602	SA8629001	4	压脚导向组件	WORK CLAMP GUIDE ASSY	
C3-03	PFHC0603	SA8597001	8	螺栓 M5×12	BOLT SOCKET M5×12	
C3-04	PFHC0604	SA8631001	2	压脚滑块	WORK CLAMP SLIDER	
C3-05	PFHC0605	SA8632001	4	滚板	CROSS ROLLER	
C3-06	PFHC0606	SA8633001	2	压脚扳手	WORK CLAMP LIFTER LEVER U	
C3-07	PFHC0607	SA8634001	2	抬压臂杆	WORK CLAMP ARM LEVER	
C3-08	PFHC0608	S55479001	2	螺栓 (带垫圈) M4×8	BOLT SOCKET (S/P WASHER)M4×8	
C3-09	PFHC0609	SA4771001	2	联接板轴	SHAFT STEPPING CLAMP LIFT LINK	
C3-10	PFHC0610	012060636	2	螺钉 M6×6	SET SCREW SOCKET (FT)M6×6	
C3-11	PFHC0611	110367001	2	垫圈 8	WASHER PLAIN SPECIAL 8	
C3-12	PFHC0612	048080142	2	轴用挡圈 C8	RETAINING RING EXTERNAL C8	
C3-13	PFHC0613	SA8635001	1	气缸轴	CYLINDER SHAFT	
C3-14	PFHC0614	012060636	2	螺钉 M6×6	SET SCREW SOCKET (FT)M6×6	
C3-15	PF9820F181	SA8636001	2	气缸组件	AIR CYLINDER ASSY	
C3-16	PFHC0615	146354002	2	垫圈 5	WASHER PLAIN 5	
C3-17	PFHC0616	048040342	2	挡圈 E4	RETAINING RING E4	
C3-18	PFHC0617	SA4720001	2	气缸接头	CYLINDER JOINT	
C3-19	PFHC0618	SA4721001	2	气缸接头轴	CYLINDER JOINT SHAFT	
C3-20	PFHC0619	048060142	4	轴用挡圈C6	RETAINING RING EXTERNAL C6	
C3-21	PFHC0621	SA8638001	1	压脚	WORK CLAMP	
C3-22	PF1310C242	S55485001	4	螺栓 (带垫圈) M5×12	BOLT SOCKET (S/P WASHER)M5×12	
C3-24	PF1310J33	S25475101	4	螺钉 M6×19	SET SCREW M6×19	
C3-25	PF1310D141	021060206	4	螺母 M6	NUT 2 M6	
C3-27	PFHC0627	SA8640001	1	压脚定位器	WORK CLAMP STOPPER	
C3-28	PFHC0628	SA8641001	1	定位橡皮	WORK CLAMP STOPPER RUBBER	
C3-29	PFHC0629	SA8820001	1	滚轮轴	ROLLER SHAFT	
C3-30	PFHC0630	048030342	2	卡簧E3	RETAINING RING E3	
C3-31	PFHC0630	SA8642001	1	蝶形螺栓	WING SCREW	
C3-32	PFHC0631	SA8643001	1	板型螺母	WORK CLAMP PLATE NUT	
C3-33	PFHC0632	SA8644001	1	板弹簧	WORK CLAMP SPRING	
C3-34	PF1310B03	SA8597001	2	螺栓M5×12	BOLT SOCKETM5×12	
C3-35	PF1310B03	S55485001	4	螺栓M5×12	BOLT SOCKET (S/P WASHER)M5×12	
C3-36	PF1790S0907	018300836	8	螺栓 M3×8	BOLT SOCKET M3×8	
C3-37	PF1790102	062500816	2	螺钉 M5×8	SCREW PAN M5×8	
C3-38	PFHC0638	SA8645001	1	管夹	HOSE SUPPORT	
C3-39	PF1310C233	S55481001	2	螺栓 (带垫圈) M4×12	BOLT SOCKET (S/P WASHER)M4×12	
C3-40	PFHC0640	SA8646001	1	压脚板组件	WORK CLAMP ASSY	
C3-42	PF1310B03	S55487001	4	螺栓 (带垫圈) M5×16	BOLT SOCKET (S/P WASHER)M5×16	
C3-43	PFHC0643	SA8648001	1	送料板	FEED PLATE	
C3-44	PF1310C242	SA8904001	2	螺栓 (带垫圈) M5×10L	BPLT SOCKET (S/P WASHER)M5×10L	

D1 . 抬压装置 / Work clamp lifter mechanism

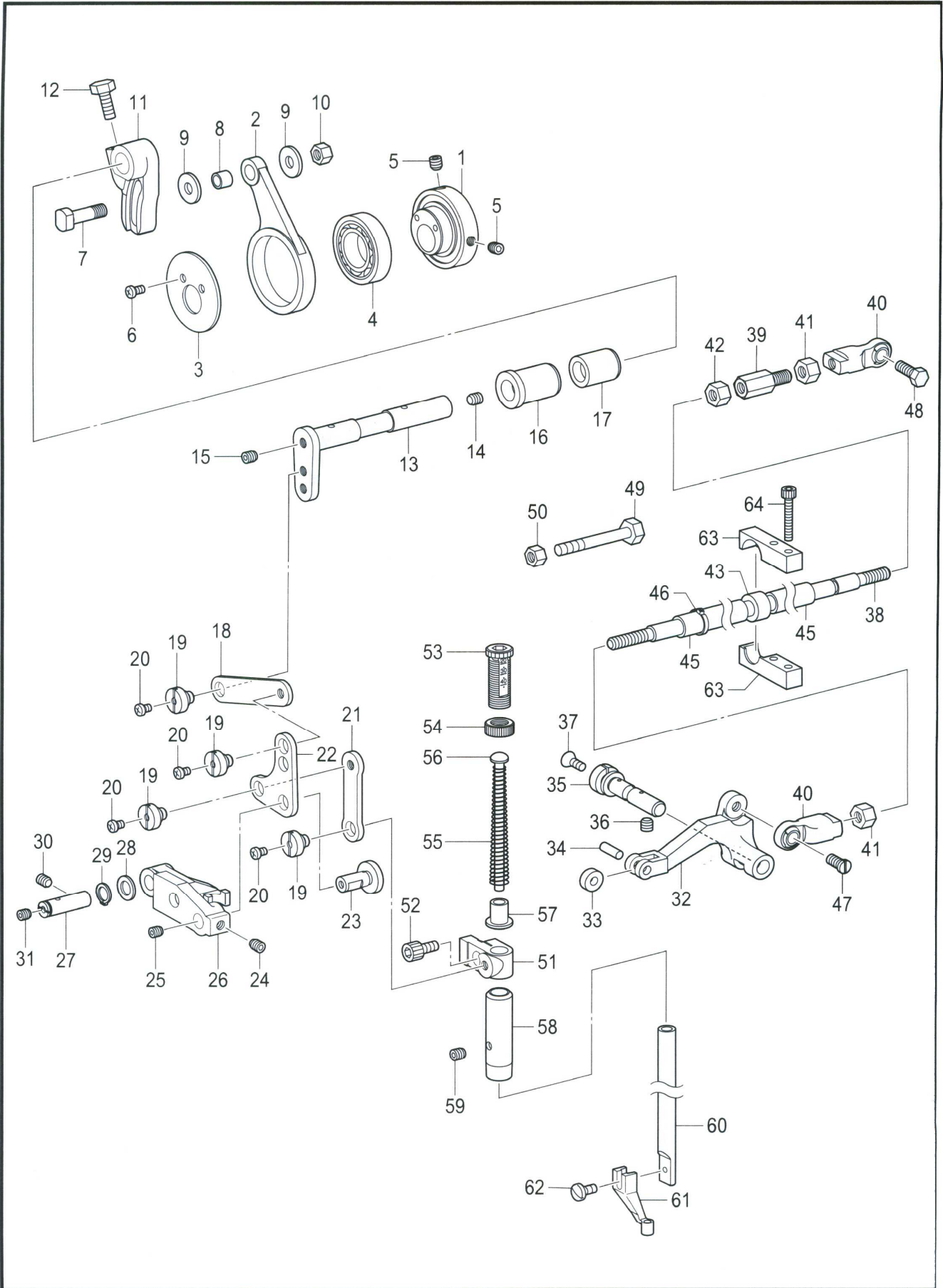

3020>D1. 抬压装置/Work clamp lifter mechanism						
序号	ERP编号	零部件序号	数量	名称	NAME OF PARTS	备注
D1-01	PF1310D101	SA4759001	1	凸轮	STEPPING CLAMP CAM	
D1-02	PF1310D102	SA4760001	1	连杆	STEPPING CLAMP CON. ROD	
D1-03	PF1310D103	SA4763001	1	垫圈 (零件)	WASHER STEPPING CLAMP CAM	
D1-04	PF1310D104	623033000	1	轴承 6805VV	BALL BEARING 6805VV	
D1-05	SCJ2033	S23651001	2	固定螺钉 M6×6	SET SCREW SOCKET (FT)M6×6	
D1-06	PF1310D106	062400616	2	螺钉 M4×6	SCREW PAN M4×6	
D1-07	PF1310D107	SA4761001	1	滚轮轴	ROLLER SHAFT STEPPING CLAMP	
D1-08	PF1310D108	SA4762001	1	滚轮	ROLLER STEPPING CLAMP	
D1-09	PF1310D109	SA4302001	2	垫圈	WASHER	
D1-10	PF19000120	021060106	1	螺母 M6	NUT 1 M6	
D1-11	PF1310D111	SA4764001	1	压臂 R	STEPPING CLAMP ARM R	
D1-12	PF1310D112	017061213	1	螺栓 M6×12	BOLT M6×12	
D1-13	PF1310D113	SA4765001	1	压臂 F	STEPPING CLAMP ARM F	
D1-14	PF1310B24	012060636	1	螺钉 M6×6	SET SCREW SOCKET (FT)M6×6	
D1-15	SCJ2033	S23651001	1	固定螺钉 M6×6	SET SCREW SOCKET (FT)M6×6	
D1-16	PF1310D116	SA4766001	1	压臂轴套 F	BUSH STEPPING CLAMP F	
D1-17	PF1310D117	SA4767001	1	压臂轴套 R	BUSH STEPPING CLAMP R	
D1-18	PF1310D118	SA4768001	1	间歇连杆 A	STEPPING CLAMP LINK A	
D1-19	PF1310D119	SA4769101	4	段螺钉 6	SHOULDER SCREW 6	
D1-20	PF1310C248	062300416	4	螺钉 M3×4	SCREW PAN M3×4	
D1-21	PF1310D121	SA4770001	1	间歇连杆 B	STEPPING CLAMP LINK B	
D1-22	PF1310D122	SA4772001	1	间歇连杆	STEPPING CLAMP LINK	
D1-23	PF1310D123	SA4773001	1	联杆轴	SHAFT STEPPING CLAMP LIFT LINK	
D1-24	PF1310B24	012060636	1	螺钉 M6×6	SET SCREW SOCKET (FT)M6×6	
D1-25	PF1310D125	012400436	1	螺钉 M4×4	SET SCREW SOCKET (FT)M4×4	
D1-26	PF1310D126	SA4777001	1	联接板	STEPPING CLAMP LIFTER LINK	
D1-27	PF1310D127	SA4771001	1	联接板轴	SHAFT STEPPING CLAMP LIFT LINK	
D1-28	PF1310D128	SA2161001	1	垫圈	WASHER	
D1-29	PF1310C311	048080142	2	轴用挡圈 C8	RETAINING RING EXTERNAL C8	
D1-30	PF1310B24	012060636	1	螺钉 M6×6	SET SCREW SOCKET (FT)M6×6	
D1-31	PF1310D125	012400436	1	螺钉 M4×4	SET SCREW SOCKET (FT)M4×4	
D1-32	PF1310D132	SA4779001	1	间歇提升杆	STEPPING CLAMP LIFTER	
D1-33	PF1310D133	SA4781001	1	提升杆滑轮	ROLLER STEPPING CLAMP LIFTER	
D1-34	PF1310D134	141362001	1	滚轮	ROLLER	
D1-35	PF1310D135	SA4780001	1	提升杆轴	SHAFT STEPPING CLAMP LIFTER	
D1-36	PF1310B24	012060636	1	螺钉 M6×6	SET SCREW SOCKET (FT)M6×6	
D1-37	PF1310D137	S25310101	1	螺钉 M4	SCREW FLAT M4	
D1-38	PFHC0738	SA8683001	1	间歇提升连杆	STEPPING CLAMP LIFTER ROD	
D1-39	PF1310D139	SA4853001	1	提升连杆接头	JOINT STEPPING CLAMP LIFTER	
D1-40	PF1310D140	SA8684001	2	球接头组件	ROUND JOINT ASSY	
D1-41	PF1310D141	021060306	2	六角螺母 M6	NUT 3 M6	
D1-42	PF1310D142	SA3227001	1	螺母 M6 细螺纹	NUT (FT) M6	
D1-43	PFHC0743	SA8688001	1	橡皮管套	RUBBER BUSH	
D1-45	PFHC0745	SA8912001	2	橡皮管	RUBBER TUBE	
D1-46	SCJ5031	S04159000	1	线夹 1M	BAND 1M	
D1-47	PF1310D143	SA8689001	1	螺钉 M6×12	SCREW M6×12	
D1-48	PF1310D144	017061612	1	六角螺栓 M6×16	BOLT M6×16	
D1-49	PF1310D145	017065002	1	螺栓 M6×50	BOLT M6×50	
D1-50	PF19000120	021060106	1	螺母 M6	NUT 1 M6	
D1-51	PF1310D147	SA4778001	1	压紧杆接头	PRESSER BAR CLAMP	
D1-52	PF1310C110	018400836	1	螺栓 M4×8	BOLT SOCKET M4×8	
D1-53	PF1310D149	SA1174001	1	调节螺栓 M14	PRESSER ADJUSTING SCREW M14	
D1-54	PF1310D150	SA1175001	1	调节螺母 M14	ADJUST SCREW NUT	
D1-55	PF1310D151	SA5300001	1	弹簧	PRESSER BAR SPRING	
D1-56	PF1310D152	S10112101	1	弹簧导向	PRESSER BAR SPRING GUIDE	
D1-57	PF1310D153	SA5301001	1	弹簧套管	COLLAR PRESSER BAR SPRING	

D1 . 抬压装置 / Work clamp lifter mechanism

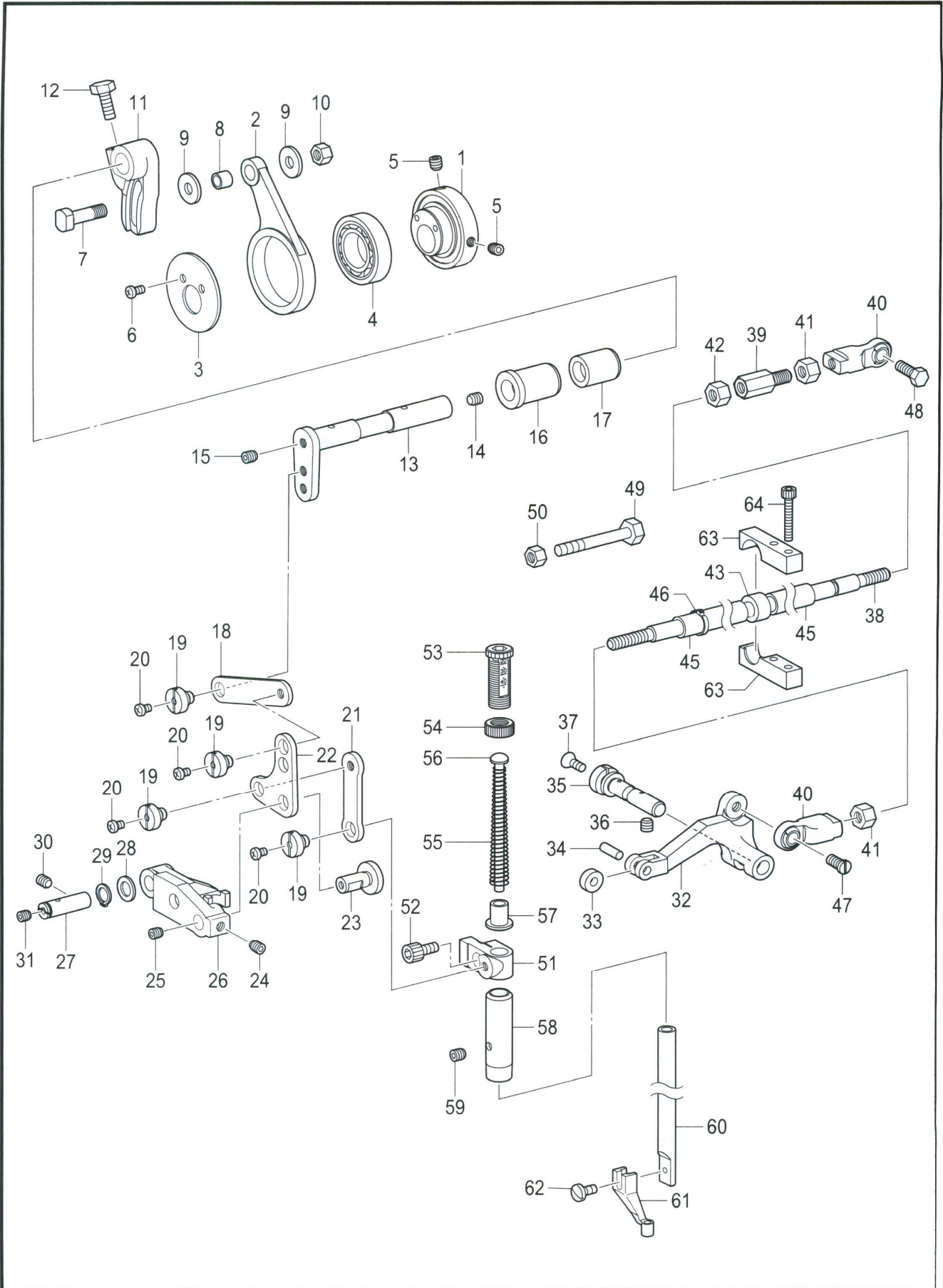

3020>D1. 抬压装置/Work clamp lifter mechanism						
序号	ERP编号	零部件序号	数量	名称	NAME OF PARTS	备注
D1-58	PF1310D154	SA2195001	1	压紧杆轴套	PRESSER BAR BUSH	
D1-59	PF1310B52	012060536	1	螺钉 M6×5	SET SCREW SOCKET (FT)M6×5	
D1-60	PF1310D156	111466121	1	压紧杆	PRESSER BAR	
D1-61	PF1310D157	S42843001	1	压脚 A	PRESSER FOOT A	
D1-62	PF1310D158	S13399001	1	螺钉 SM3. 57×12	SCREW SM3. 57×12	
D1-63	PFHC0763	SA8690001	2	间歇提升连杆支架	HOLDER STEP-CLAMP LIFTER ROD	
D1-64	PFHC0764	018402536	2	螺栓 M4×25	BOLT SOCKET M4×25	

D2 . 抬压装置 / Work clamp lifter mechanism

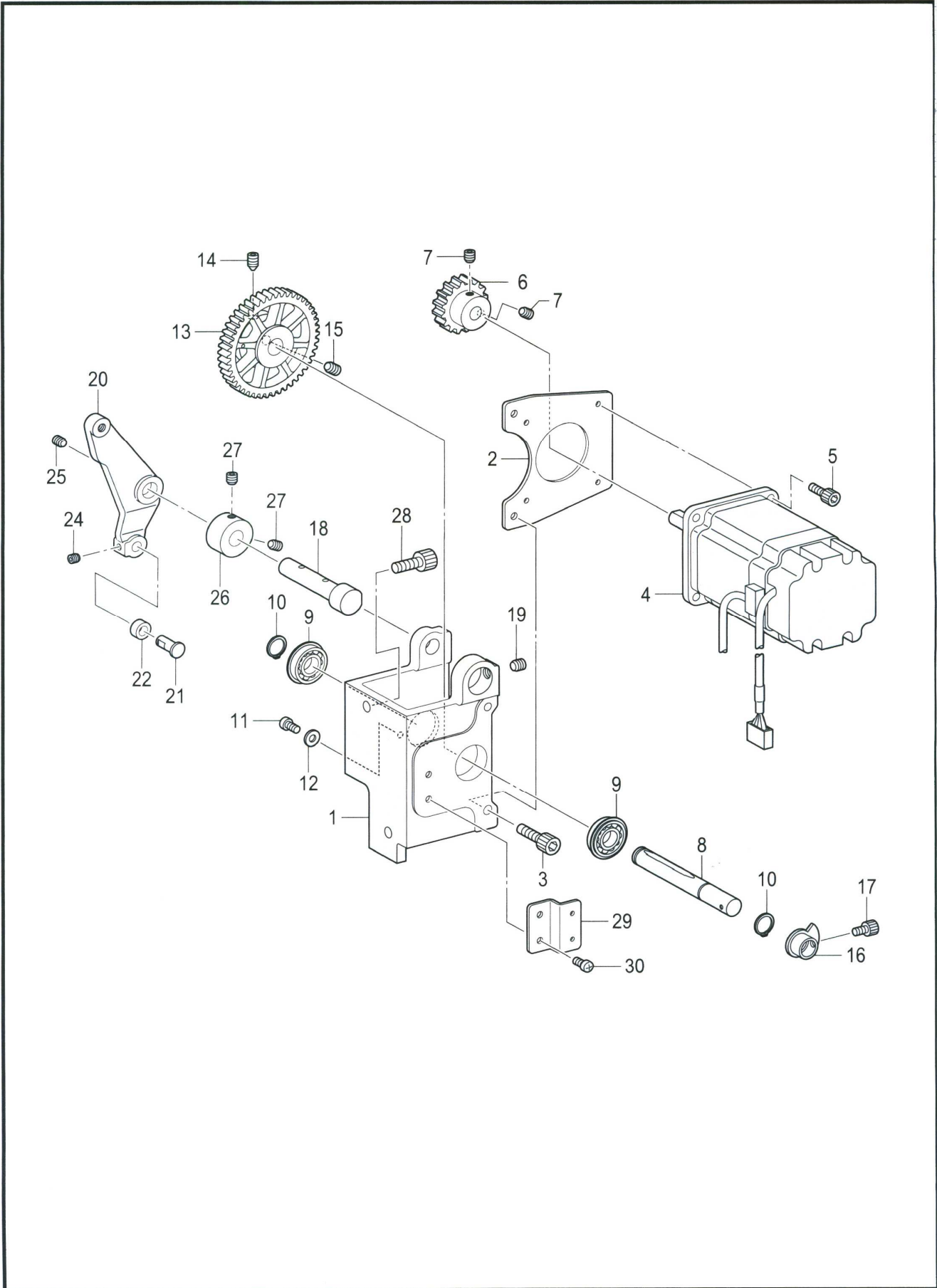

3020>D2. 抬压装置/Work clamp lifter mechanism						
序号	ERP编号	零部件序号	数量	名称	NAME OF PARTS	备注
D2-01	PF1310D218	SA4741101	1	马达座	MOTOR BRACKET	
D2-02	PF1310D219	SA4742001	1	压脚马达板	WORK CLAMP MOTOR PLATE	
D2-03	PF1310C266	018501036	2	螺钉 M5×10	BOLT SOCKET M5×10	
D2-04	PFHC0804	SA4826501	1	脉冲马达组件 P	PULSE MOTOR ASSY P	
D2-05	PF1310C252	018401036	4	螺栓 M4×10	BOLT SOCKET M4×10	
D2-06	PF1310D224	SA4743001	1	驱动齿轮	WORK CLAMP DRIVING GEAR	
D2-07	PF1310B24	012060636	2	螺钉M6×6	SET SCREW SOCKET (FT) M6×6	
D2-08	PF1310D226	SA4744001	1	压脚支点轴	WORK CLAMP FULCRUM SHAFT	
D2-09	PF1310C127	SA4647001	2	球轴承 6900ZZNR	BALL BEARING 6900ZZNR	
D2-10	PF9820E11	048100142	2	轴用挡圈 C10	RETAINING RING EXTERNAL C10	
D2-11	PF1310D106	062400616	1	螺钉 M4×6	SCREW PAN M4×6	
D2-12	PF1310C136	025040236	1	平垫圈 M4	WASHER PLAIN M4	
D2-13	PF1310D231	SA4745001	1	凸轮齿轮	WORK CLAMP CAM GEAR	
D2-14	PF1310D232	016061031	1	螺钉 M6×10	SET SCREW SOCKET(CN)M6×10	
D2-15	PF1310B24	012060636	1	螺钉 M6×6	SET SCREW SOCKET (FT) M6×6	
D2-16	PF1310D238	SA4747001	1	压脚原点挡块	WORK CLAMP H-POSITION DOG	
D2-17	PF1310D239	018400636	1	螺栓 M4×6	BOLT SOCKET M4×6	
D2-18	PF1310D240	SA4748101	1	压脚柄轴	WORK CLAMP LEVER SHAFT	
D2-19	PF1310B24	012060636	1	螺钉 M6×6	SET SCREW SOCKET (FT) M6×6	
D2-20	PF1310D242	SA6210001	1	间歇驱动杆	STEPPING W-CLAMP DRIVING LEVER	
D2-21	PF1310D243	SA3441001	1	抬压滚轮轴	W-CLAMP LIFTER ROLLER SHAFT	
D2-22	PF1310D244	070696800	1	轴承 R-696ZZ	BALL BEARING RADIAL 696ZZ	
D2-24	BF310164514	012500536	1	螺钉 M5×5	SET SCREW SOCKET(FT)M5×5	
D2-25	PF1310B24	012060636	1	螺钉 M6×6	SET SCREW SOCKET (FT) M6×6	
D2-26	PF1310D333	SA4757101	1	紧圈	SET SCREW COLLAR	
D2-27	PF1310B24	012060636	2	螺钉 M6×6	SET SCREW SOCKET (FT) M6×6	
D2-28	PF1310A37	018061236	2	螺栓 M6×12(三合一)	BOLT SOCKET M6×12	
D2-29	PF1310D255	SA4753001	1	压脚传感器板	WORK CLAMP SENSOR PLATE	
D2-30	PF1310D106	062400616	2	螺钉 M4×6	SCREW PAN M4×6	

E . 下轴装置 / Lower shaft mechanism

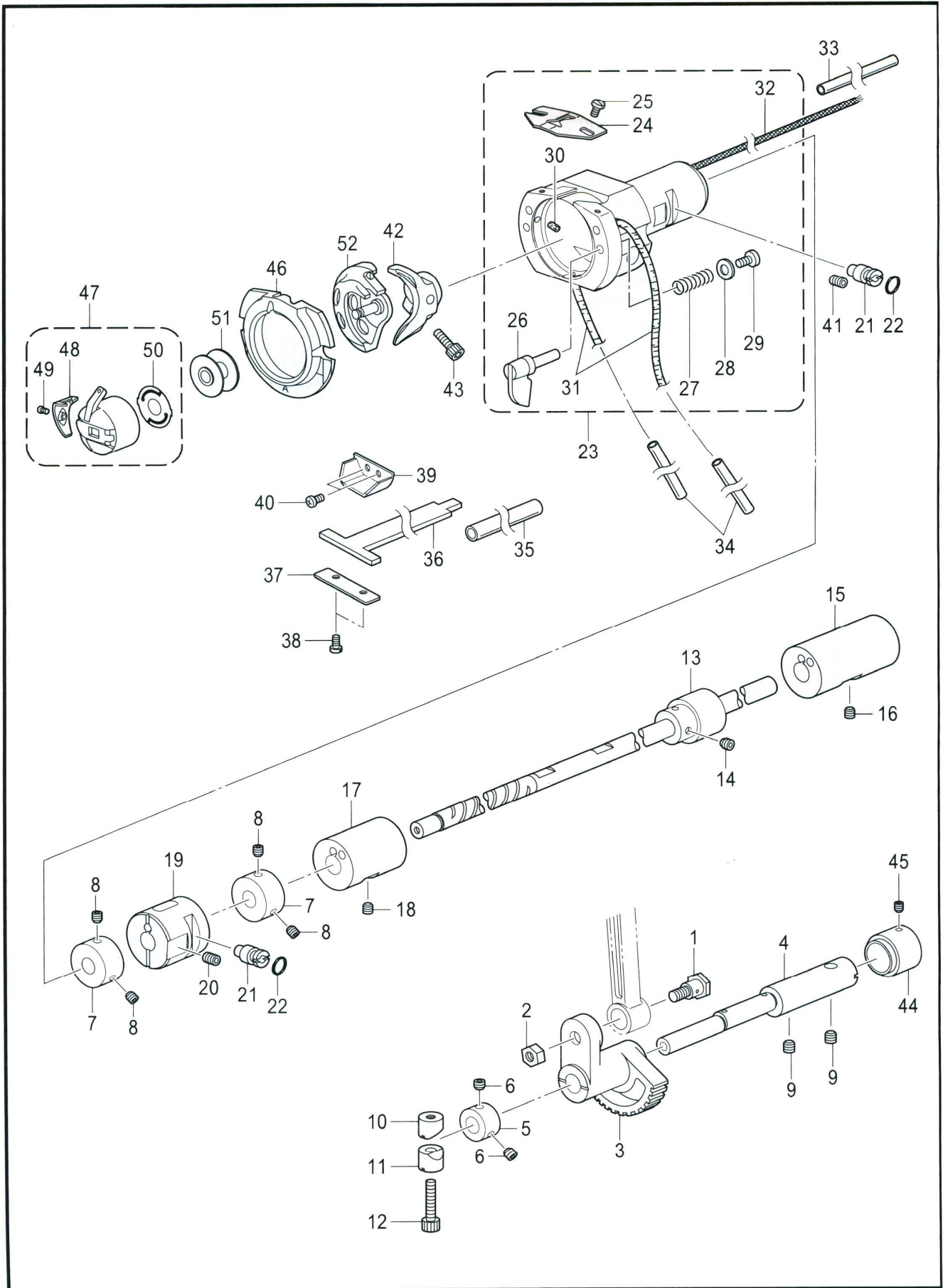

3020>E. 下轴装置/Lower shaft mechanism						
序号	ERP编号	零部件序号	数量	名称	NAME OF PARTS	备注
E-01	PF1310E01	SA3226001	1	段螺钉	SHOULDER SCREW	
E-02	PF1310D142	SA3227001	1	螺母 M6	NUT(FT) M6	
E-03	PF1310E03	SA3228001	1	摆动齿轮	ROCK GEAR	
E-04	PF1310E04	SA4782001	1	摆动齿轮轴	ROCK GEAR SHAFT	
E-05	PF1310E05	SA3231001	1	紧圈 B	SET SCREW COLLAR B	
E-06	PF1310B52	012060536	2	螺钉 M6×5	SET SCREW SOCKET (FT)M6×5	
E-07	PFHC0907	SA8695001	2	紧圈	SET SCREW COLLAR	
E-08	SCJ2033	S23651001	4	固定螺钉 M6×6	SET SCREW SOCKET (FT)M6×6	
E-09	PF1310B24	012060636	2	螺钉 M6×6	SET SCREW SOCKET (FT)M6×6	
E-10	PFHC0910	SA8696001	1	紧固管套 A	PINCH SLEEVE A	
E-11	PFHC0911	SA8697001	1	紧固管套 B	PINCH SLEEVE B	
E-12	PF1310C131	018402036	1	螺栓 M4×20	BOLT SOCKET M4×20	
E-13	PFHC0913	SA8698001	1	下轴组件	LOWER SHAFT ASSY	
E-14	BF310164514	012500536	1	螺钉 M5×5	SET SCREW SOCKET (FT)M5×5	
E-15	PFHC0915	SA8701001	1	下轴轴套	LOWER SHAFT BUSH	
E-16	PF1310B24	012060636	1	螺钉 M6×6	SET SCREW SOCKET (FT)M6×6	
E-17	PFHC0917	SA8702001	1	下轴中轴套	LOWER SHAFT M BUSH	
E-18	PF1310B24	012060636	1	螺钉 M6×6	SET SCREW SOCKET (FT)M6×6	
E-19	PFHC0919	SA8703001	1	下轴调整轴套	LOWER SHAFT A-BUSH	
E-20	PF1310E30	012061036	1	螺钉 M6×10	SET SCREW SOCKET (FT)M6×10	
E-21	PF1310E14	SA3238101	2	旋梭调节轴	ADJUSTING STUD	
E-22	PF1310E15	081003670	2	O形圈PW3	O RING PW3	
E-23	PFHC0923	SA8705001	1	旋梭基座组件	SHUTTLE RACE BASE ASSY	
E-24	PFHC0924	S02429201	1	旋梭线导向	SHUTTLE RACE THREAD GUIDE	
E-25	PFHC0925	SA4199001	2	螺钉 M3×4	SCREW M3×4	
E-26	PFHC0926	SA3241001	2	大旋梭固定柄	S-RACE BASE SETTING CLAW	
E-27	PFHC0927	152684101	2	弹簧	COMPRESSION SPRING	
E-28	PFHC0928	026030136	2	平垫圈 S3	WASHER PLAIN S3	
E-29	PFHC0929	062300616	2	螺钉 M3×6	SCREW PAN M3×6	
E-30	PFHC0930	153050000	2	油毡	S-RACE BASE FELT	
E-31	PFHC0931	SA8707001	2	油毡	FELT	
E-32	PFHC0932	SA9004001	1	油线 6×6	WICK 6×6	
E-33	PFHC0933	SA8709001	1	油管	OIL TUBE	
E-34	PFHC0934	SA8710001	2	油管	OIL TUBE	
E-35	PFHC0935	SA8711001	1	油管	OIL TUBE	
E-36	PFHC0936	SA8712101	1	油毡	FELT	
E-37	PFHC0937	SA8713001	1	油毡支撑板	FELT HOLDER	
E-38	PFHC0938	S44924001	2	固定螺钉 M3×5.5	SCREW M3×5.5	
E-39	PFHC0939	SA3274101	1	油毡支架	FELT HOLDER	
E-40	PFHC0940	S47307001	2	螺钉 M3×4	SCREW M3×4	
E-41	PF1310E30	012061036	1	螺钉 M6×10	SET SCREW SOCKET (FT)M6×10	
E-42	PF1310E32	SA3284101	1	梭托 D	DRIVER D	
E-43	PF1310J48	018501236	1	螺栓 M5×12	BOLT SOCKET M5×12	
E-44	PF1310E40	SA3283101	1	紧圈 R	SET SCREW COLLAR R	
E-45	BF310164514	012500536	1	螺钉 M5×5	SET SCREW SOCKET (FT)M5×5	
E-46	PFHC0946	152686201	1	外旋梭 B	SHUTTLE RACE BASE B	
E-47	PF1310E35	S59221201	1	梭芯套组件 LC	BOBBIN CASE ASSY LC	
E-48	PFHC0948	S48664001	1	夹线簧 AN	TENSION SPRING AN	
E-49	PFHC0949	S16492101	1	螺钉	BOBBIN CASE SPRING SCREW	
E-50	PFHC0950	S15667001	1	防空转弹簧	ANTI-SPIN SPRING	
E-51	PF1310E39	S44633001	1	梭芯 LAN	BOBBIN LAN	
E-52	PF1310E42	SA8197101	1	中旋梭组件	SHUTTLE HOOK ASSY W/BOXSA8196	

F . 供油润滑装置 / Lubrication

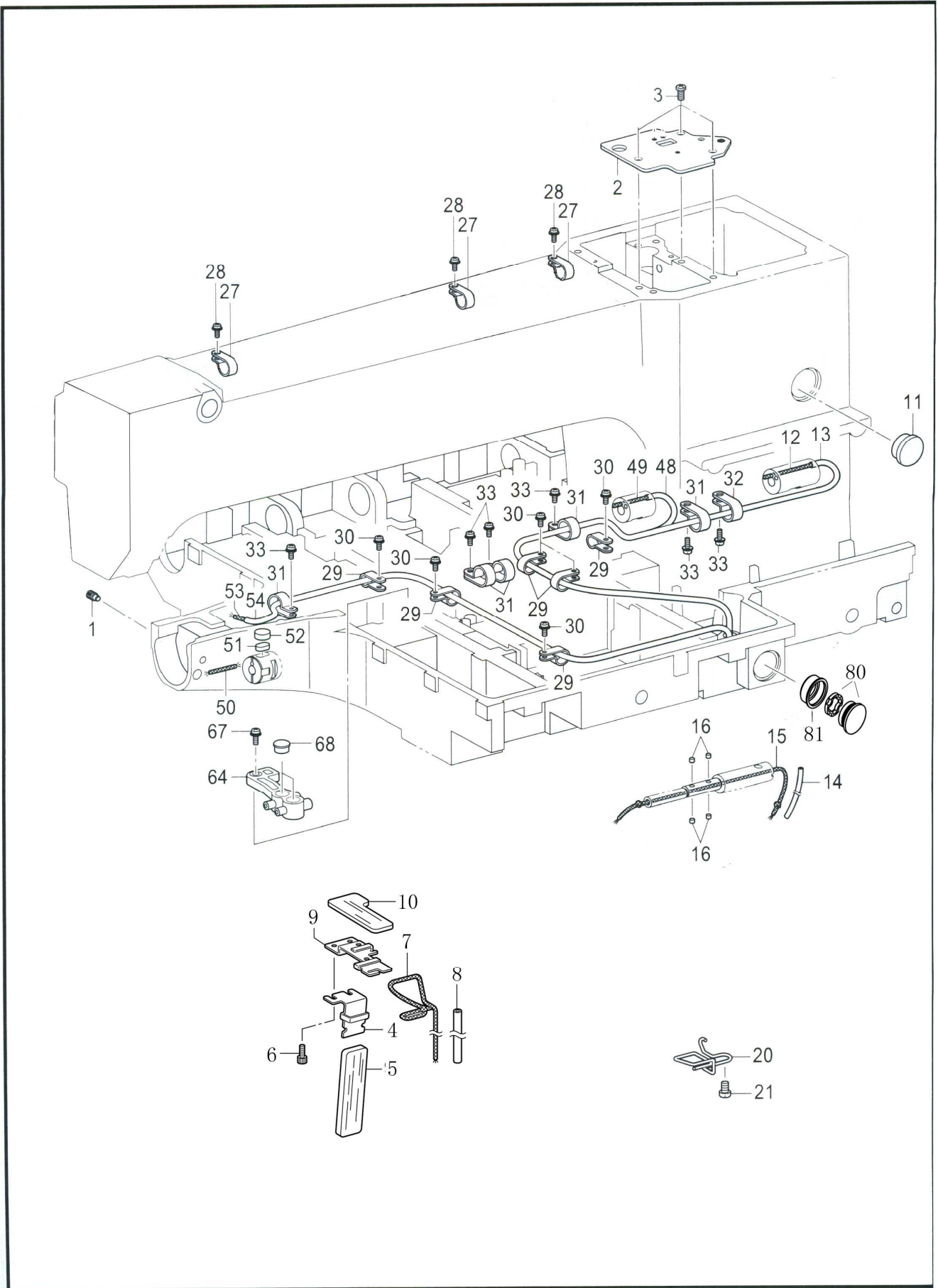

3020>F. 供油润滑组件/Lubrication						
序号	ERP编号	零部件序号	数量	名称	NAME OF PARTS	备注
F-01	PF1310F01	SA3244001	1	螺钉	SET SCREW	
F-02	PF1310F02	SA4785101	1	曲柄盖	CRANK COVER	
F-03	PF8420M-D30846	062061016	3	螺钉 M6×10	SCREW PAN M6×10	
F-04	PF1310F08	062400616	1	下轴给油支架	LOWER SHAFT WICK SUPPORT	
F-05	PF1310F09	SA4786101	1	下轴齿轮油毡	LOWER SHAFT GEAR FELT	
F-06	PF1310D239	SA8714001	1	螺栓 M4×6	BOLT SOCKET M4×6	
F-07	PF69349	018400636	1	油线 L=680	WICK L=680	
F-08	SCJ5011	062400616	1	油管 L=450	OIL TUBE L=450	
F-09	PF1310F30	SA6087001	1	齿轮供油支架	GEAR WICK SUPPORT	
F-10	PF1310F31	104567101	1	油毡	GEAR FELT	
F-11	PF1310A43	152948001	1	橡皮塞 29	OIL GAUGE WINDOW	
F-12	PF69349	SA8783001	1	油线 6×6	WICK 6×6	
F-13	SCJ5030	SA8784001	1	油管	OIL TUBE	
F-14	SCJ5030	SA5072001	1	油管 L=120	OIL TUBE L=120	
F-15	PF69349	SA6578001	1	油线 6×6 L=300	WICK 6×6 L=300	
F-16	PF1310F27	S09043000	4	滤油毡(L=5)	FELT	
F-19	PFHC1019	SA5339101	1	油管嘴	OIL FEEDING PIPE	
F-20	PF1310F32	SA4789101	1	油线夹 B	LOWER SHAFT WICK SUPPORT B	
F-21	PF8420M-D30846	062060816	1	螺钉 M6×8	SCREW PAN M6×8	
F-27	SCJ5034	525567000	5	电线夹 #8	CORD HOLDER #8	
F-28	PF1310C233	0A5401006	5	螺栓(带垫圈) M4×10DB	SCREW PAN(S/P WASHER)M4×10	
F-29	SCJ5034	525567000	7	电线夹 #8	CORD HOLDER #8	
F-30	PF1310C233	0A5401006	6	螺栓(带垫圈) M4×10DB	SCREW PAN(S/P WASHER)M4×10	
F-31	SCJ5035	552907000	5	电线夹 #10	CORD HOLDER #10	
F-32	SCJ5035	554482000	1	电线夹 #10	CORD HOLDER #12	
F-33	PF1310C110	0A5401006	6	螺栓(带垫圈) M4×10DB	SCREW PAN(S/P WASHER)M4×10	
F-40	SCJ5030	SA6576001	1	油管 L=210	OIL TUBE L=210	
F-45	PFHC1045	SA8722001	1	油管嘴	OIL FEEDING PIPE	
F-48	SCJ5030	SA8725001	4	油管	OIL TUBE	
F-49	PF69349	SA8726001	1	油线 6×6	WICK 6×6	
F-50	PF69349	SA8727001	1	油线 6×6	WICK 6×6	
F-51	PFHC1051	SA8728001	1	油毡	FELT	
F-52	PFHC1052	SA8729001	1	油毡	FELT	
F-53	PF5550833	SA8708001	1	油线 6×6	WICK 6×6	
F-54	SCJ5030	SA8785001	1	油管	OIL TUBE	
F-67	PF1310C110	0A5401006	1	螺栓(带垫圈) M4×10DB	SCREW PAN(S/P WASHER)M4×10	
F-68	PF9820Z85	SA2929001	2	橡皮塞 12.5	RUBBER CAP 12.5	
F-76	PFHC1076		2	油管接头转接头		
F-80	PF1310F20		1	油视窗	OIL GAUGE WINDOW	
F-81	PF1310F70		1	橡皮衬套	RUBBER CAP	

G. 穿线装置 / Threading mechanism

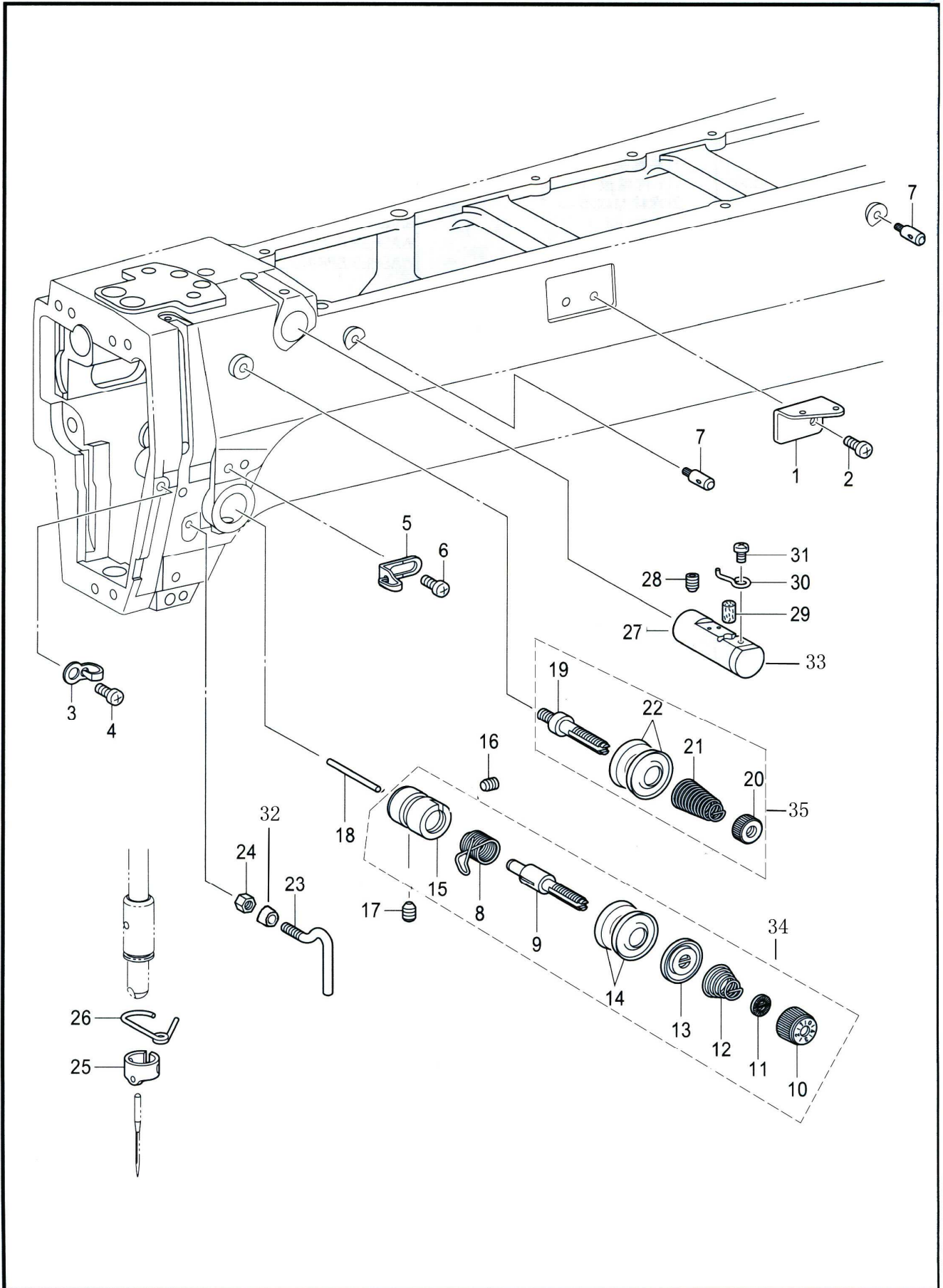

3020>G. 穿线装置/Threading mechanism						
序号	ERP编号	零部件序号	数量	名称	NAME OF PARTS	备注
G-01	PF1310G01	SA3250001	1	过线导向 A	ARM THREAD GUIDE A	
G-02	PF8420M-D3010112	062500616	1	螺钉 M5×6	SCREW PAN M5×6	
G-03	PF1310G03	SA4333001	1	过线导向 B	ARM THREAD GUIDE B	
G-04	PF8420M-D3010112	062500616	1	螺钉 M5×6	SCREW PAN M5×6	
G-05	PF1310G05	SA6391001	1	过线器 C	ARM THREAD GUIDE C	
G-06	PF8420M-D3010112	062500616	1	螺钉 M5×6	SCREW PAN M5×6	
G-07	PF1310G07	153049001	2	面线导向杆	UPPER THREAD GUIDE STUD	
G-08	PFHC1108	144588301	1	挑线弹簧 B	THREAD TAKE-UP SPRING B	
G-09	PFHC1109	SA3255001	1	夹线杆轴	TENSION STUD	
G-10	PFHC1110	S31032001	1	压线螺母	TENSION NUT	
G-11	PFHC1111	S12441001	1	止动垫圈	WASHER	
G-12	PFHC1112	107606001	1	调节弹簧	TENSION SPRING H	
G-13	PFHC1113	159805001	1	夹线压盘	TENSION DISC PRESSER	
G-14	PFHC1114	145446001	2	夹线盘	DISC TENSION	
G-15	PFHC1115	SA3254001	1	夹线座	TENSION BRACKET	
G-16	PFHC1116	100402004	1	固定螺钉 SM3. 57	SET SCREW SM3. 57	
G-17	PF1310G15	SA4143001	1	螺钉 M6×6	SET SCREW(FT)M6×6	
G-18	PF1310G16	S12699000	1	松线销	TENSION RELEASE PIN	
G-19	PFHC1119	SA3256001	1	夹线轴 A	TENSION STUD A	
G-20	PFHC1120	100136001	1	夹线螺母	TENSION NUT	
G-21	PFHC1121	SA4146101	1	弹簧	SUB TENSION SPRING	
G-22	PFHC1122	145446001	2	夹线盘	DISC TENSION	
G-23	PFHC1123	SA8691001	1	机壳线钩	THREAD GUIDE ARM	
G-24	PF1310L06	021400306	1	六角螺母 M4	NUT 3 M4	
G-25	PF1310G20	SA3257101	1	针杆线导向 A	NEEDLE BAR THREAD GUIDE A	
G-26	PF1310G21	SA3258001	1	针杆轴套线导向 D	N-BAR BUSH THREAD GUIDE D	
G-27	PF1310G22	152881001	1	线冷却器组件	NEEDLE COOLER ASSY	
G-28	PF1310B24	012060636	1	螺钉 M6×6		
G-29	PF1310G24	152883000	1	油毡 8×15.5	SET SCREW SOCKET(FT)M6×6	
G-30	PF1310G25	152884001	1	过线钩	FELT 8×15.5	
G-31	PF1310G26	062670412	1	螺钉 SM3. 57-40×4	NEEDLE COOLER THREAD GUIDE	
G-32	PFHC1132		1	橡皮垫	SCREW PAN SM3. 57-40×4	
G-33	PF1310G33		1	线冷却器盖		
G-34	PF1310G3101		1	夹线器组件A		
G-35	PF1310G32		1	夹线器组件		

H. 卷线装置 / Bobbin winder mechanism

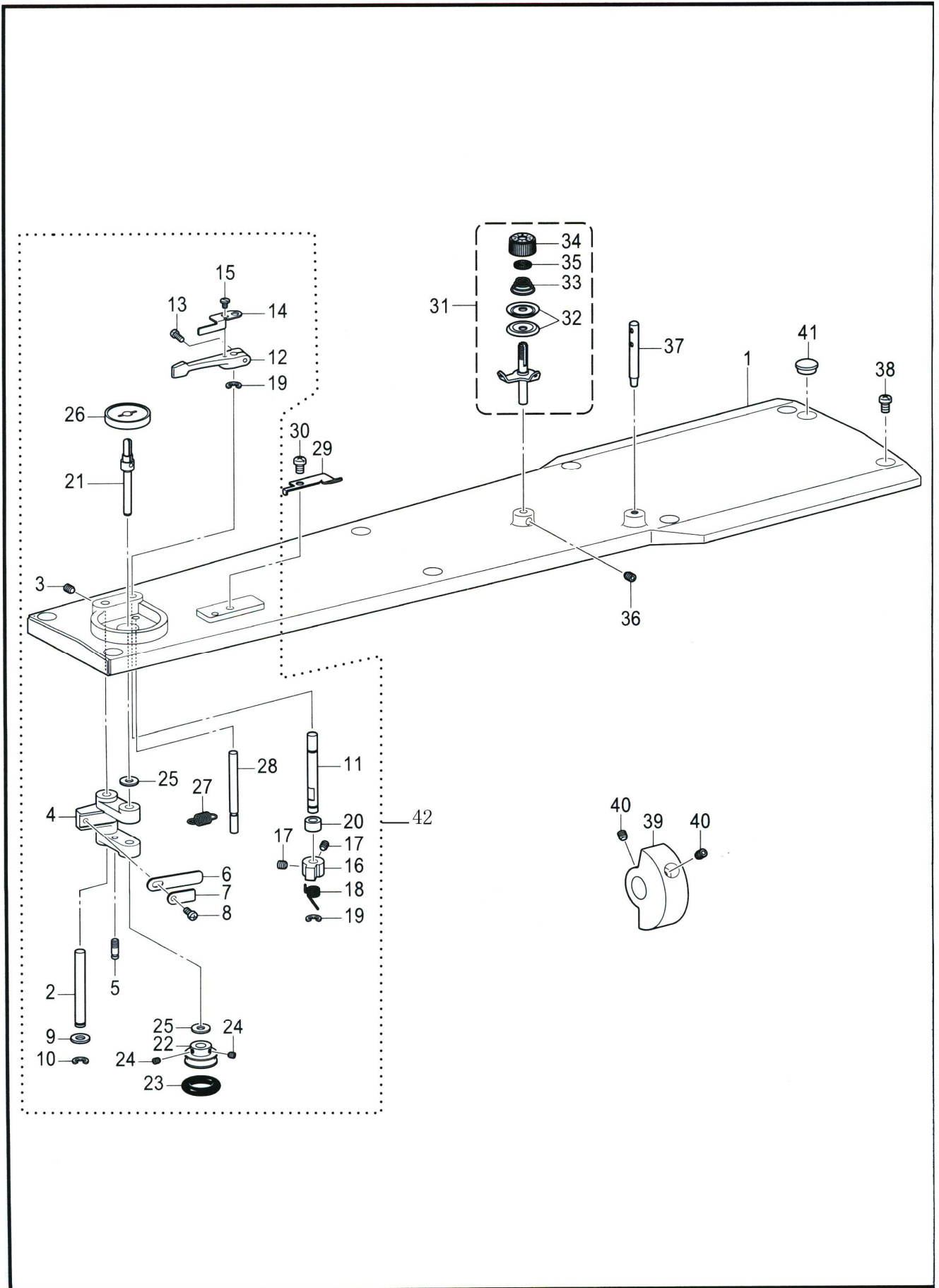

3020>H. 卷线装置/Bobbin winder mechanism						
序号	ERP编号	零部件序号	数量	名称	NAME OF PARTS	备注
H-01	PFHC1201	SA8650001	1	上盖	TOP COVER	
H-02	PF1310H02	SA3290001	1	卷线手柄轴	SHAFT BW-LEVER	
H-03	PF1310H03	012500536	1	螺钉 M5×5	SET SCREW SOCKET (FT)M5×5	
H-04	PF1310H04	SA3291001	1	卷线手柄	BOBBIN WINDER LEVER	
H-05	PF1310H05	SA4171001	1	弹簧挂钩	SPRING HOOK	
H-06	PF1310H06	152936001	1	板弹簧	PLATE SPRING	
H-07	PF1310H07	152937001	1	垫圈	WASHER	
H-08	PF1310H08	062350616	1	螺钉 M3.5×6	SCREW PAN M3.5×6	
H-09	PF1310H09	159486001	1	垫圈	WASHER	
H-10	PF1310H10	048050342	1	挡圈 E5	RETAINING RING E5	
H-11	PF1310H11	SA3293001	1	卷线卡爪轴	STUD B-WINDER CLAW	
H-12	PF1310H12	SA1984001	1	梭芯压臂柄	BOBBIN PRESSER ARM	
H-13	PF1310H13	062401216	1	螺钉 M4×12	SCREW PAN M4×12	
H-14	PF1310H14	SA3294001	1	梭芯压杆	BOBBIN PRESSER	
H-15	PF1310H15	S23418002	1	螺钉 M4×5	SCREW M4×5	
H-16	PF1310H16	SA3295001	1	卷线卡爪	CLAW B-WINDER	
H-17	PF1310H17	012400436	2	螺钉 M4×4	SET SCREW SOCKET (FT)M4×4	
H-18	PF1310H18	S10438001	1	弹簧	SPRING TWIST	
H-19	PF1310H19	048050342	2	挡圈 E5	RETAINING RING E5	
H-20	PF1310H20	SA4796001	1	垫圈 (零件)	SPACER COLLER	
H-21	PF1310H21	SA3296001	1	卷线轴	BOBBIN WINDER SHAFT	
H-22	PF1310H22	SA3297001	1	卷线器	WHEEL B-WINDER	
H-23	PF1310H23	120448001	1	橡皮圈	BOBBIN WINDER RUBBER BAND	
H-24	PF1310H24	012400436	2	螺钉 M4×4	SET SCREW SOCKET (FT)M4×4	
H-25	PF1310H25	159486001	2	垫圈	WASHER	
H-26	PF1310H26	SA1988001	1	梭芯座	BOBBIN SUPPORT	
H-27	PF1310H27	S10268001	1	拉簧	SPRING	
H-28	PF1310H28	SA3298001	1	止动轴	STOPPER SHAFT B-WINDER	
H-29	PF1310H29	SA3299001	1	切刀	KNIFE	
H-30	PF8420M-D3010112	062500616	1	螺钉 M5×6	SCREW PAN M5×6	
H-31	PF1310H31	SA1994101	1	卷线器夹线组件	BOBBIN WINDER TENSION ASSY	
H-32	PF1310H32	145446002	2	夹线盘	DISC TENSION	
H-33	PF1310H33	100401022	1	夹线弹簧	TENSION SPRING	
H-34	PF1310H34	S31032001	1	压线螺母	TENSION NUT	
H-35	PF1310H35	S12441001	1	止动垫圈	WASHER	
H-36	BF310164514	012500536	1	螺钉 M5×5	SET SCREW SOCKET (FT)M5×5	
H-37	PFHC1237	SA1359001	1	穿线杆	SPOOL PIN	
H-38	PF8420M-D30846	062061016	6	螺钉 M6×10	SCREW PAN M6×10	
H-39	PF1310H38	SA4797101	1	卷线驱动轮	DRIVING WHEEL B-WINDER	
H-40	SCJ2033	S23651001	2	固定螺钉 M6×6	SET SCREW SOCKET (FT)M6×6	
H-41	PF1310A04	117934001	1	橡皮塞 13.5	RUBBER CAP 13.5	
H-42	PF1310H4001		1	卷线组件		

J. 切线装置 / Thread trimmer mechanism

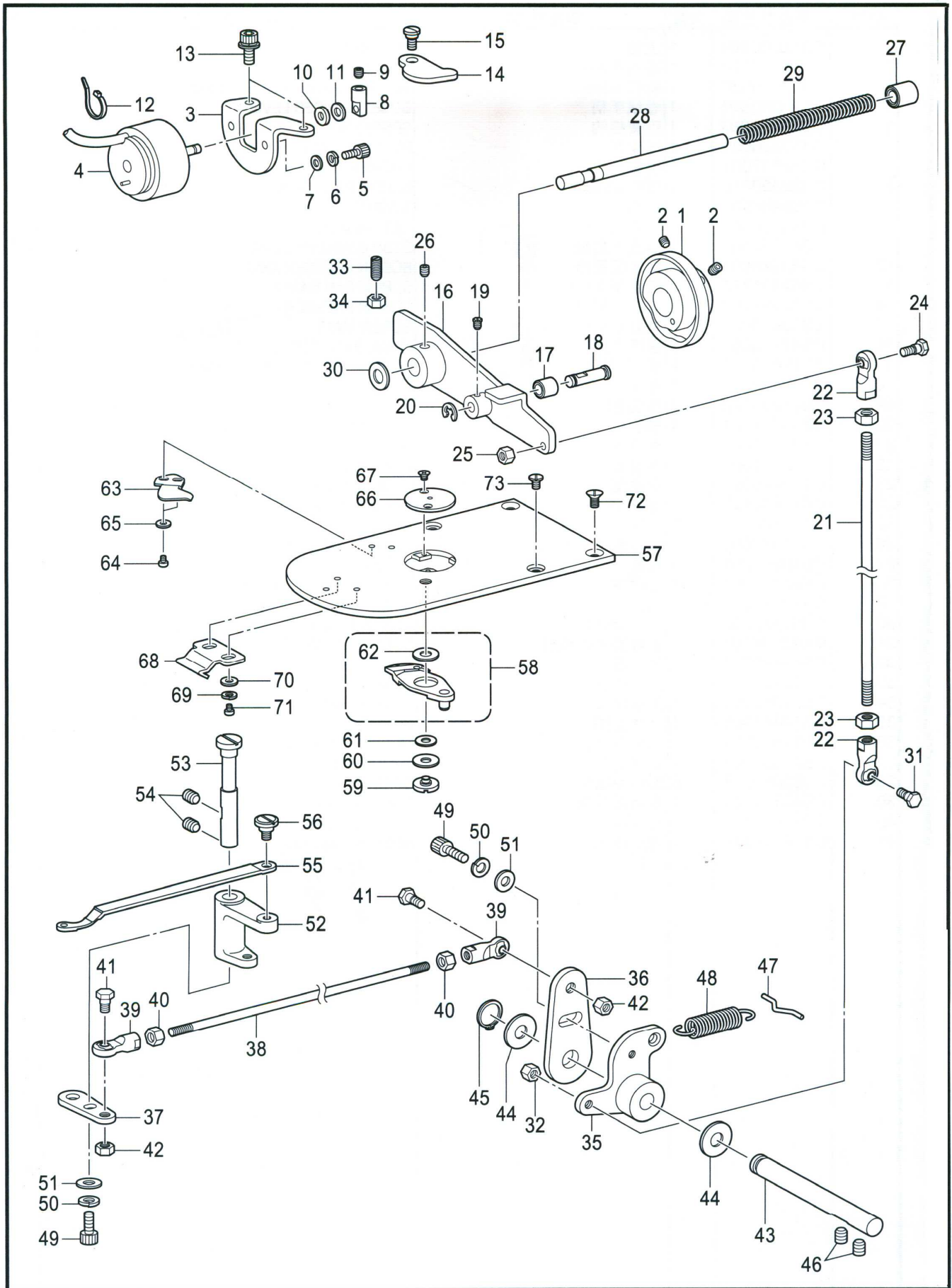

3020>J. 切线装置/Thread trimmer mechanism						
序号	ERP编号	零部件序号	数量	名称	NAME OF PARTS	备注
J-01	PF1310J01	SA3301101	1	切线凸轮	THREAD TRIMMER CAM	
J-02	SCJ2033	S23651001	2	固定螺钉 M6×6	SET SCREW SOCKET (FT)M6×6	
J-03	PF1310J03	SA4798001	1	电磁铁安装板	SETTING PLATE SOLENOID	
J-04	PF1310J04	SA5135101	1	切线电磁铁	THREAD TRIMMER SOLENOID	
J-05	PF1310L06	017400802	2	螺母M4	BOLT M4×8	
J-06	PF1310C137	028040246	2	弹簧垫圈 2-4	WASHER SPRING 2-4	
J-07	PF1310C136	026040236	2	平垫圈 M4	WASHER PLAIN M4	
J-08	PF1310J08	SA3307001	1	电磁铁杆	SOLENOID LEVER	
J-09	PF1310D125	012400436	1	螺钉 M4×4	SET SCREW SOCKET (FT)M4×4	
J-10	PF1310J10	154599000	1	电磁铁缓冲垫圈	SOLENOID CUSHION	
J-11	PF1310J11	S02652001	1	垫圈	WASHER	
J-12	SCJ5031	S04159000	1	线夹 1M	BAND 1M	
J-13	PF1310C242	S55484002	2	螺栓 (带垫圈) M5×10	BOLT SOCKET (S/P WASHER)M5×10	
J-14	PF1310J14	SA4799001	1	驱动压杆	PUSHING LEVER D-LEVER	
J-15	PF1310A26	SA3306001	1	段螺钉 7-3	SHOULDER SCREW 7-3	
J-16	PF1310J16	SA3309101	1	切线驱动杆	TR-DRIVING LEVER	
J-17	PF1310J17	SA3310001	1	切线滚轮	COLLAR TR-TRIMMER	
J-18	PF1310J18	SA3311001	1	切线滚轮轴	COLLAR SHAFT	
J-19	PF1310J19	S46903001	1	螺钉 M4×5	SET SCREW M4×5	
J-20	PF1310J20	048040342	1	挡圈 E4	RETAINING RING E4	
J-21	PF1310J21	SA3315001	1	切线杆 V	THREAD TRIMMER ROD V	
J-22	PF1310J22	S32465101	2	接头组件	BALL JOINT ASSY	
J-23	PF19000120	021060106	2	螺母 M6	NUT 1 M6	
J-24	PF1310D144	S32462001	1	段螺钉 B M6	SHOULDER SCREW B M6	
J-25	PF1310D141	021060306	1	六角螺母 M6	NUT 3 M6	
J-26	SCJ2033	S23651001	1	固定螺钉 M6×6	SET SCREW SOCKET (FT)M6×6	
J-27	PF1310J27	231071001	1	轴套 8×15	BUSH 8×15	
J-28	PF1310J28	SA3312201	1	驱动杆导向轴	GUIDE SHAFT	
J-29	PF1310J29	SA3313101	1	弹簧	SPRING COMPRESSION	
J-30	PF1310J30	154596000	1	减震垫圈	CUSHION	
J-31	PF1310D144	S32462001	1	段螺钉 B M6	SHOULDER SCREW B M6	
J-32	PF1310D141	021060306	1	六角螺母 M6	NUT 3 M6	
J-33	PF1310J33	S25475101	1	螺钉 M6×19	SET SCREW M6×19	
J-34	PF19000120	021060106	1	螺母 M6	NUT 1 M6	
J-35	PF1310J35	SA4546001	1	切线杠杆 V	THREAD TRIMMER LEVER V	
J-36	PF1310J36	SA3317001	1	切线杠杆 H	THREAD TRIMMER LEVER H	
J-37	PFHC1337	SA8652001	1	动刀杠杆 D	MOVING KNIFE	
J-38	PFHC1338	SA8654001	1	切线杆 H	THREAD TRIMMER ROD H	
J-39	PF1310J22	S32465101	2	接头组件	BALL JOINT ASSY	
J-40	PF19000120	021060106	2	螺母 M6	NUT 1 M6	
J-41	PF1310D144	S32462001	2	段螺钉 B M6	SHOULDER SCREW B M6	
J-42	PF1310D141	021060306	2	六角螺母 M6	NUT 3 M6	
J-43	PF1310J42	SA3319101	1	切线杠杆轴	SHAFT TR-TRIMMER LEVER	
J-44	PF1310J43	SA4545001	2	垫片	SPACER	
J-45	PF1310C311	048080142	1	轴用挡圈 C8	RETAINING RING EXTERNAL C8	
J-46	PF1310B24	012060636	2	螺钉M6×6	SET SCREW SOCKET (FT) M6×6	
J-47	PFHC1347	SA8655001	1	弹簧挂钩	SPRING HOOK	
J-48	PF1310J47	SA3321001	1	切线复位弹簧	SPRING EXTENSION	
J-49	PF1310C242	018501236	2	螺栓 M5×12	BOLT SOCKET M5×12	
J-50	PF1310C336	028050246	2	弹簧垫圈 2-5	WASHER SPRING 2-5	
J-51	PF1310J50	146354002	2	垫圈 5	WASHER PLAIN 5	
J-52	PFHC1352	SA8656001	1	动刀杆	MOVING KNIFE LEVER	
J-53	PFHC1353	SA8657001	1	动刀杆轴	SHAFT MOVABLE KNIFE LEVER	
J-54	PF1310B24	012060636	2	螺钉M6×6	SET SCREW SOCKET (FT) M6×6	
J-55	PFHC1355	SA8658101	1	动刀连杆	M-KNIFE CONNECTING PLATE	
J-56	PF1310J56	SA4354001	1	段螺钉 6-1.8	SHOULDER SCREW 6-1.8	

J. 切线装置 / Thread trimmer mechanism

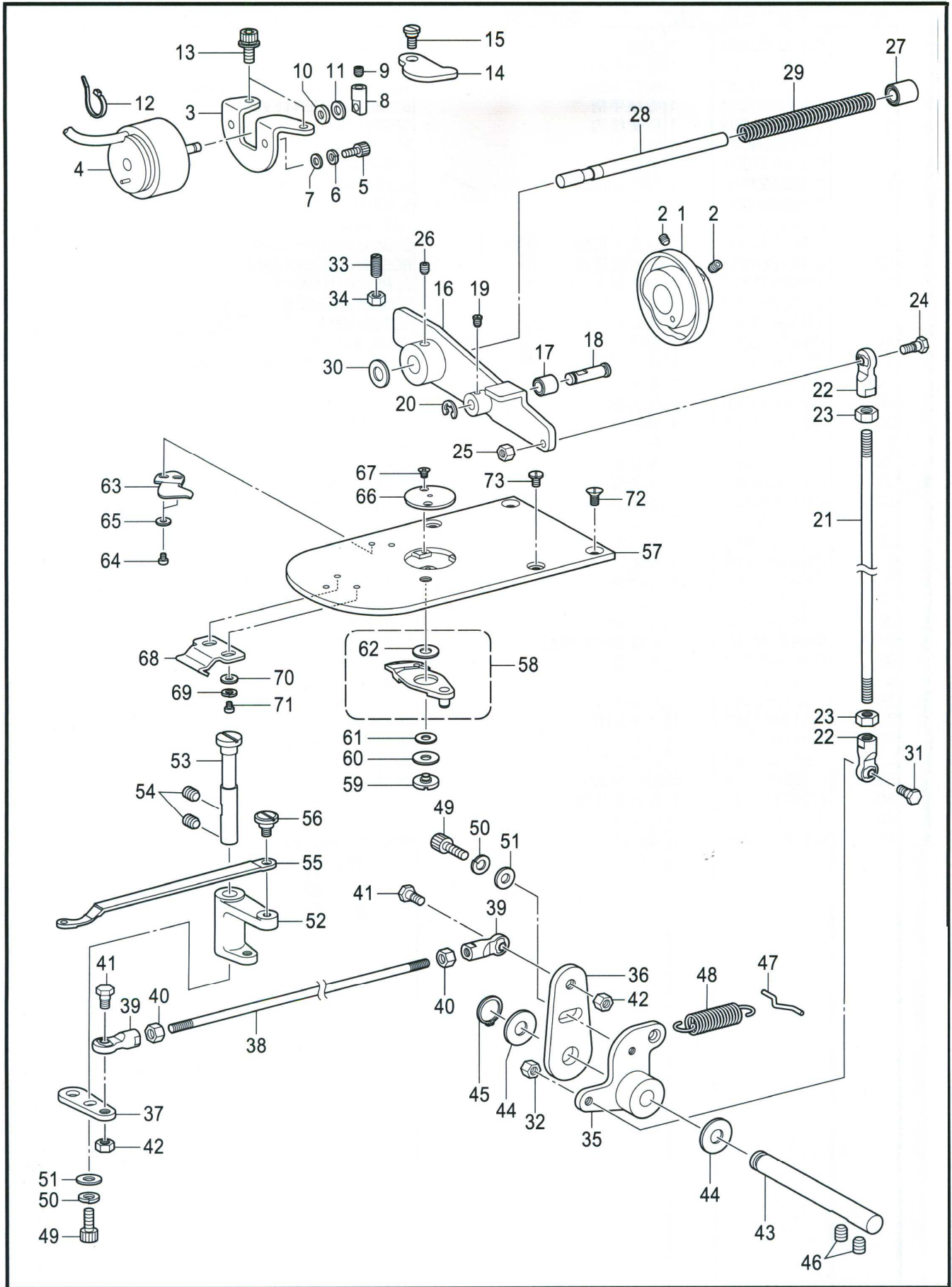

3020>J. 切线装置/Thread trimmer mechanism						
序号	ERP编号	零部件序号	数量	名称	NAME OF PARTS	备注
J-57	PF1310J5701	SA5157101	1	针板 A	NEEDLE PLATE A	
J-58	PF1310J58	SA6596001		动刀复合件 F	MOVABLE KNIFE SET F	
J-59	PF1310J59	SA4518001		段螺钉	MOVABLE KNIFE SHOULDER SCREW	
J-60	PF1310J60	SA4519001		轴向垫圈	THRUST WASHER	
J-61	PF1310J61	S00705001		动刀圈套	MOVABLE KNIFE COLLAR	
J-62	PF1310J62	SA6398001		垫片 0.4	M-KNIFE SPACER T0.2	
J-63	PF1310J63	SA7944001		固定刀 FL	FIXED KNIFE FL	
J-64	PF1310J64	062300416		螺钉 M3×4	SCREW PAN M3×4	
J-65	PF1310J65	025030236		平垫圈 M3	WASHER PLAIN M3	
J-66	PF1310J66	SA3336101		针板孔 2.4C0.4	NEEDLE HOLE PLATE 2.4C0.4	
J-67	PF1310J67	100360003		螺钉 SM2.38	SCREW	
J-68	PF1310J68	SA6273101		大旋梭挂钩 U	SHUTTLE RACE COVER HOOK U	
J-69	PF1310J69	028030246		弹簧垫圈 2-3	WASHER SPRING 2-3	
J-70	PF1310J70	025030236		平垫圈 M3	WASHER PLAIN M3	
J-71	PF1310J71	062300416		螺钉 M3×4	SCREW PAN M3×4	
J-72	PF1310D137	S25310101	2	螺钉 M4	SCREW FLAT M4	
J-73	PF1310J69	SA3538001	2	螺钉 M4×8	SCREW M4×8	

K. 扫线装置 / Thread wiper mechanism

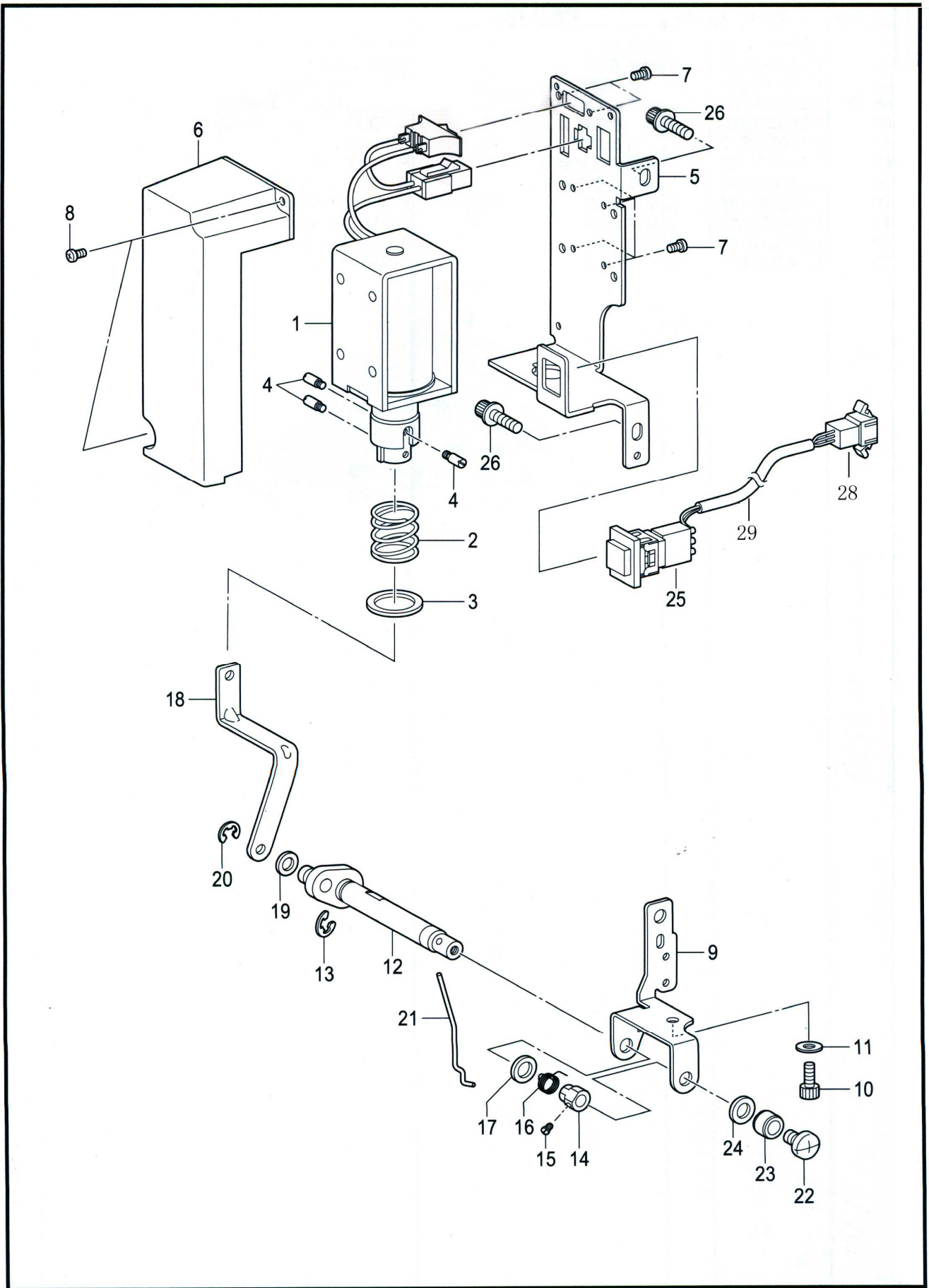

3020>K. 扫线装置/Thread wiper mechanism						
序号	ERP编号	零部件序号	数量	名称	NAME OF PARTS	备注
K-01	PF1310K01	SA5208001	1	扫线电磁铁组件	THREAD WIPER SOLENOID ASSY	
K-02	PF1310K02	S41206001	1	扫线弹簧	THREAD WIPER SPRING	
K-03	PF1310K03	S41205001	1	平垫圈	WASHER PLAIN	
K-04	PF1310K04	S25456001	3	柱塞销	PLUNGER PIN	
K-05	PF1310K05	SA5217001	1	扫线电磁铁安装板	T-WIPER SOLENOID SETTING PLATE	
K-06	PF1310K06	SA4806001	1	电磁铁盖	SOLENOID COVER	
K-07	PF1310E22	062300616	4	螺钉 M3×6	SCREW PAN M3×6	
K-08	PF1310E22	044300606	2	螺钉 M3×6DA	SCREW PAN(S/P WASHER)M3×6	
K-09	PF1310K08	SA5218001	1	扫线轴托架	THREAD WIPER SHAFT BRACKET	
K-10	PF1310C110	018400836	1	螺钉 M4×8	BOLT SOCKET M4×8	
K-11	PF1310C136	025040236	1	平垫圈 M4	WASHER PLAIN M4	
K-12	PF1310K11	SA8057001	1	扫线曲柄组件	THREAD WIPER CRANK ASSY	
K-13	PF1310J20	048040342	1	挡圈 E4	RETAINING RING E4	
K-14	PF1310K13	S25454001	1	螺纹紧圈	SET SCREW COLLAR	
K-15	PF1310K14	S25279101	1	螺钉 M3. 5-5	SET SCREW(CP)M3. 5-5	
K-16	PF1310K15	SA2287001	1	弹簧	SPRING	
K-18	PF1310K17	SA5219001	1	扫线连杆	THREAD WIPER ROD	
K-19	PF1310K18	110735001	1	垫圈	WASHER	
K-20	PF1310K19	048030342	1	挡圈 E3	RETAINING RING E3	
K-21	PF1310K20	S10470201	1	扫线杆	WIPER	
K-22	PF1310K21	060400516	1	螺钉 M4×5	SCREW BIND M4×5	
K-23	PF1310K22	146288001	1	挡线轴挡圈	THREAD WIPER STUD COLLAR	
K-24	PF1310K23	S03677001	1	垫圈	WASHER	
K-25	PF1310K24	SA5213001	1	急停开关按键	STOP SWITCH ASSY	
K-26	PF1310C242	S55485001	2	螺栓（带垫圈）M5×12	BOLT SOCKET(S/P WASHER)M5×12	
K-28	PF1310K28			急停开关插头	Emergency stop switch plug	
K-29	PF1310K29			急停开关线	Emergency stop switch line	

L . 松线装置 / Tension release mechanism

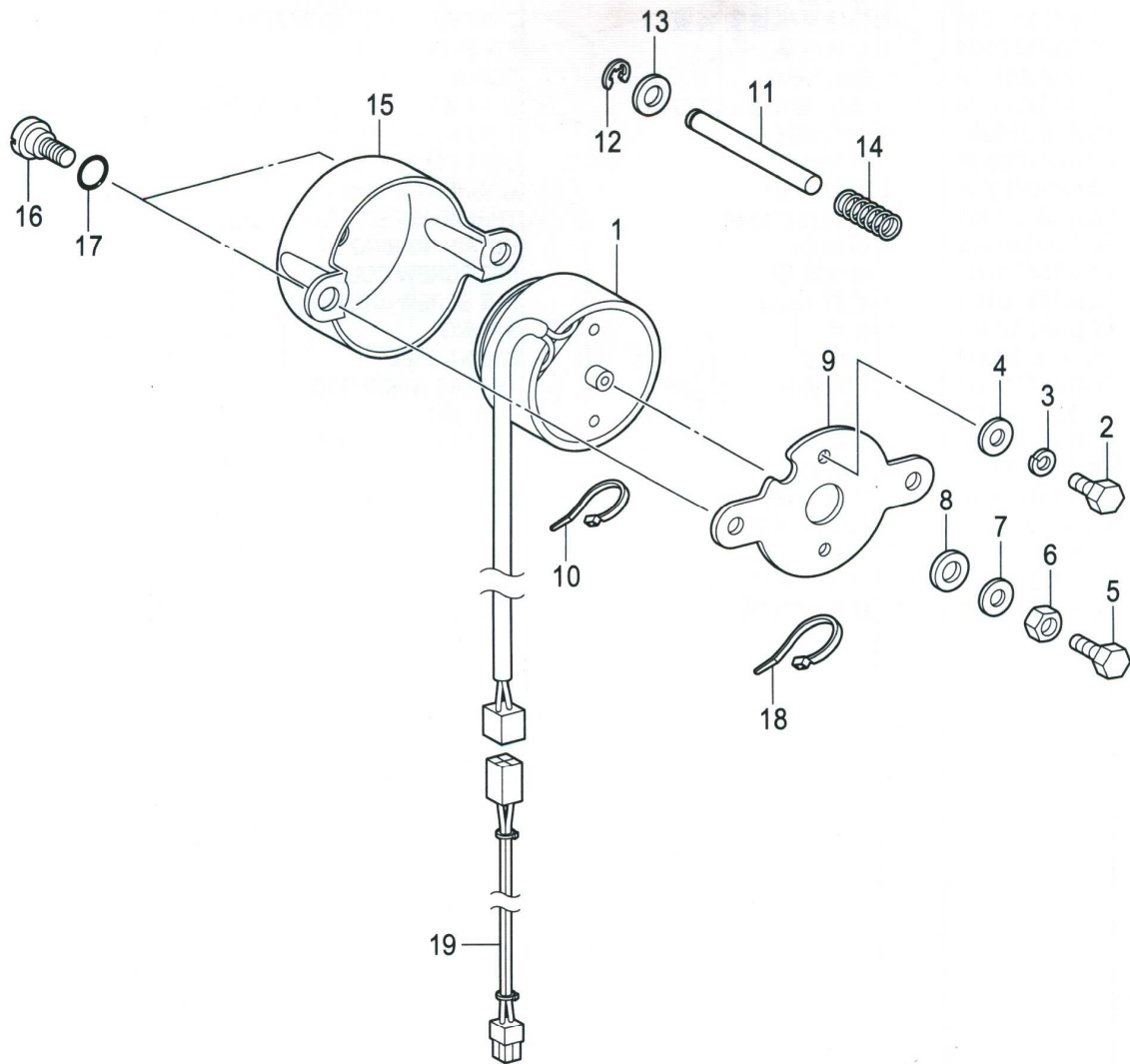

3020>L. 松线装置/Tension release mechanism						
序号	ERP编号	零部件序号	数量	名称	NAME OF PARTS	备注
L-01	PF1310L01	SA4855001	1	松线电磁铁 HV	TENSION RELEASE SOLENOID HV	
L-02	PF1310J05	017400802	2	螺栓 M4×8	BOLT M4×8	
L-03	PF1310C137	028040246	2	弹簧垫圈 2-4	WASHER SPRING 2-4	
L-04	PF1310C136	026040236	2	平垫圈 M4	WASHER PLAIN M4	
L-05	PF1310L05	017401415	1	螺栓 M4×14	BOLT M4×14	
L-06	PF1310L06	021400306	1	六角螺母 M4	NUT 3 M4	
L-07	PF1310L07	102707002	1	垫圈	WASHER	
L-08	PF1310J10	154599000	1	电磁铁缓冲垫圈	SOLENOID CUSHION	
L-09	PF1310L09	SA6389001	1	电磁铁安装板	SETTING PLATE SOLENOID	
L-10	SCJ5031	S04159000	1	线夹 1M	BAND 1M	
L-11	PF1310L11	SA3347001	1	松线杆	TENSION RELEASE BAR	
L-12	PF1310J20	048040342	1	挡圈 E4	RETAINING RING E4	
L-13	PF1310J50	025050236	1	平垫圈 M5	WASHER PLAIN M5	
L-14	PF1310L14	SA3348001	1	弹簧	SPRING COMPRESSION	
L-15	PF1310L15	SA3349001	1	电磁铁盖	SOLENOID COVER	
L-16	PF1310A26	SA3306001	2	段螺钉 7-3	SHOULDER SCREW 7-3	
L-17	PF22840525	081007070	2	O形圈 P7	O RING P7	
L-18	SCJ5031	S04159000	1	线夹 1M	BAND 1M	

P . 空压装置 / Air pressure mechanism

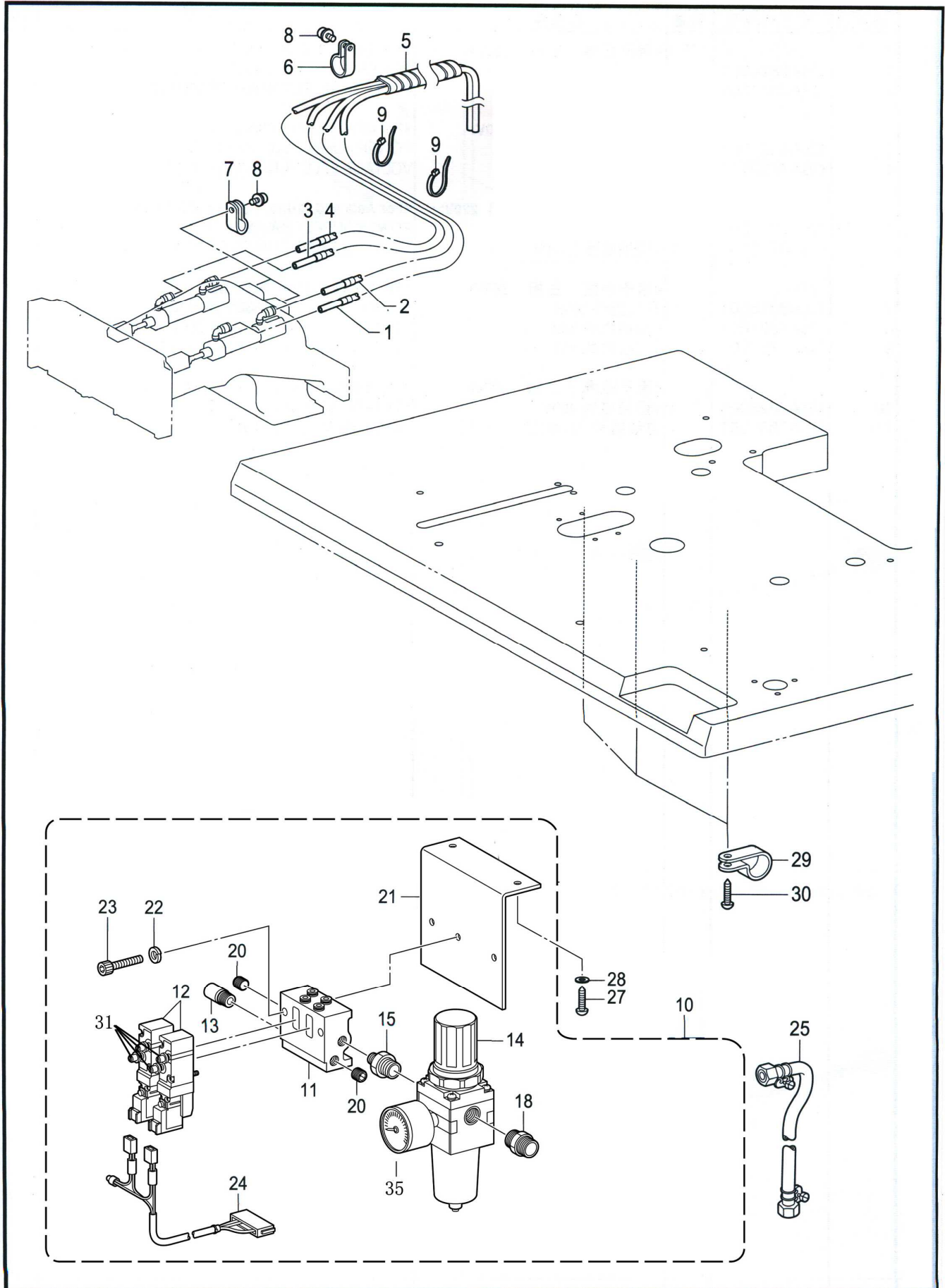

3020>P. 空压装置/Air pressure mechanism						
序号	ERP编号	零部件序号	数量	名称	NAME OF PARTS	备注
P-01	M91149	SA8659001	1	空气管R	Air pipe R	
P-02	M91149	SA8659002	1	空气管R	Air pipe R	
P-03	M91149	SA8660001	1	空气管L	Air pipe L	
P-04	M91149	SA8660002	1	空气管L	Air pipe L	
P-05	SCJ5005	SA8661001	2	螺旋管线650S	Spiral pipeline 650s	
P-06	SCJ5033	525664000	1	电线夹 #6	Wire clamp #6	
P-07	SCJ5033	149547000	2	压线板	Crimping plate	
P-08	PF1310C233	0A5401005	5	螺栓（带垫圈）M4×10DB	Bolt (with washer) M4 × 10DB	
P-09	SCJ5031	228475000	2	电线夹1.9X80	Wire clip 19X80	
P-11	PF1310M02	SA5289001	1	集合管2	Manifold 2	
P-12	PF1310M03	S39116100	2	阀VQZ2151S-5	Valve vqz2151s-5	
P-13	PF1310M03	SA5283001		消音器AN103-1	Silencer an103-1	
P-14	PF1310M05	SA5282001	1	调整器AW20-02G	Regulator aw20-02g	
P-15	PF1310M06	S09228000		管接头	Pipe joint	
P-18	PF1310M09	SA5285001	1	中间接头1/4	Intermediate joint 1 / 4	
P-20	PF1310M11	153274001		盖 1/8	Cover 1 / 8	
P-21	PF1310M12	SA5286101	1	阀安装板	Valve mounting plate	
P-24	PF1310M30	SA5191001		阀门接线2连组	Valve wiring 2 groups	
P-27	SCJ2095	032422003	2	木螺钉 M4. 1×20	Wood screw M4. 1X20	
P-28	SCJ3007	148847001	2	垫圈	Washer	
P-29	SCJ5035	554482000	3	电线夹 #12	Wire clamp #12	
P-30	SCJ2095	032422003	3	木螺钉 M4. 1×20	Wood screw M4. 1X20	
P-31	PFM91161		4	阀气管接头	Valve air pipe connector	
P-35	PF1310M35		1	压力表	Pressure gauge	

Q . 电气部品装置 / Power supply equipment mechanism

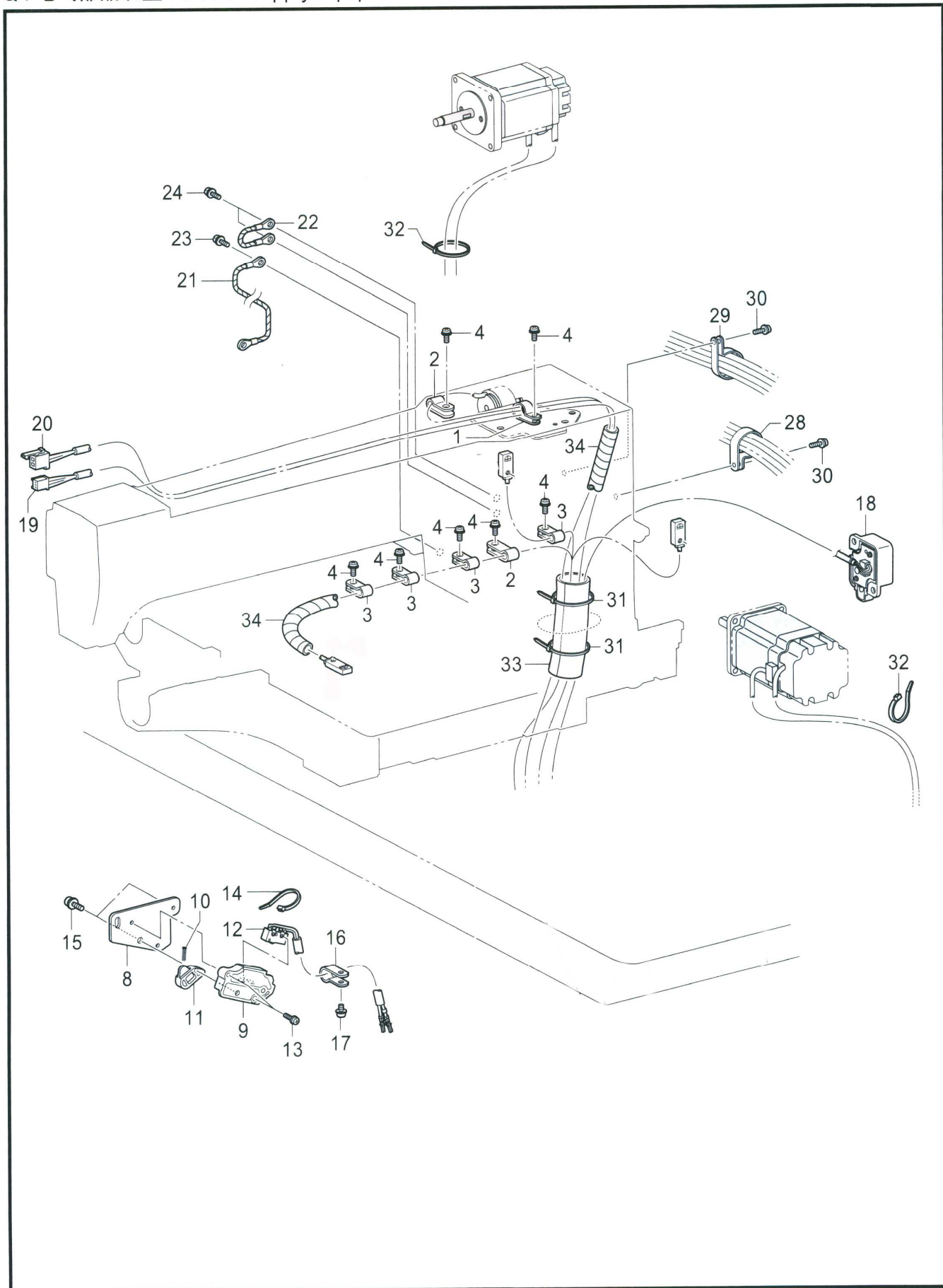

3020>Q. 电气部品装置/Power supply equipment mechanism						
序号	ERP编号	零部件序号	数量	名称	NAME OF PARTS	备注
Q-01	SCJ5034	525567000	1	电线夹 #8	Wire clamp #8	
Q-02	SCJ5033	149547000	2	电线夹 #6	Wire clamp #6	
Q-03	SCJ5033	625010000	4	电线夹 #6	Wire clamp #6	
Q-04	PF1310C233	0A5401006	5	螺钉带垫圈M4×10DB	washer M4 × 10DB	
Q-08	PFHC2008	SA8523001	1	安全开关板T3020	Safety switch board t3020	
Q-09	PF9820V11	SA5730101	1	开关基座	Switch base	
Q-10	PF9820V12	SA5731001	1	开关弹簧	Switch spring	
Q-11	PF9820V13	SA5732101	1	开关手柄	Switch handle	
Q-12	PFHC2012	SA8524001	1	安全开关组件	Safety switch assembly	
Q-13	PF1900A0319	SA7293001	2	螺栓（带垫圈）M3×12	Bolt (with washer) M3 × 12	
Q-14	SCJ5031	S04159000	1	线夹 1M	Clamp 1m	
Q-15	PF1310C233	0A5401006	2	螺栓（带垫圈）M4×10DB	Bolt (with washer) M4 × 10DB	
Q-16	SCJ5033	149547000	1	电线夹 #6	Wire clamp #6	
Q-17	PF1310C233	0A5401006	1	内六角螺钉M4X8（三合一）	screw M4x8 (three in one)	
Q-23	PF1310C233	0A5401006	2	内六角螺钉M4X8（三合一）	screw M4x8 (three in one)	
Q-28	SCJ5035	554482000	1	电线夹 #12	Wire clamp #12	
Q-29	SCJ5036	S00470000	1	电线夹 #16	Wire clamp #16	
Q-30	PF1310C233	0A5401006	2	螺钉带垫圈M4×10DB	washer M4 × 10DB	
Q-31	SCJ5031	218859001	2	线夹 M150	Clamp m150	
Q-32	SCJ5031	S04159000	3	线夹 1M	Clamp 1m	
Q-33	SCJ5005	SA8881001	1	粘链管	Adhesive chain tube	
Q-34	SCJ5005	SA6366001	1	螺旋管线140S	Spiral pipeline 140s	

Z . 附件 / Accessories

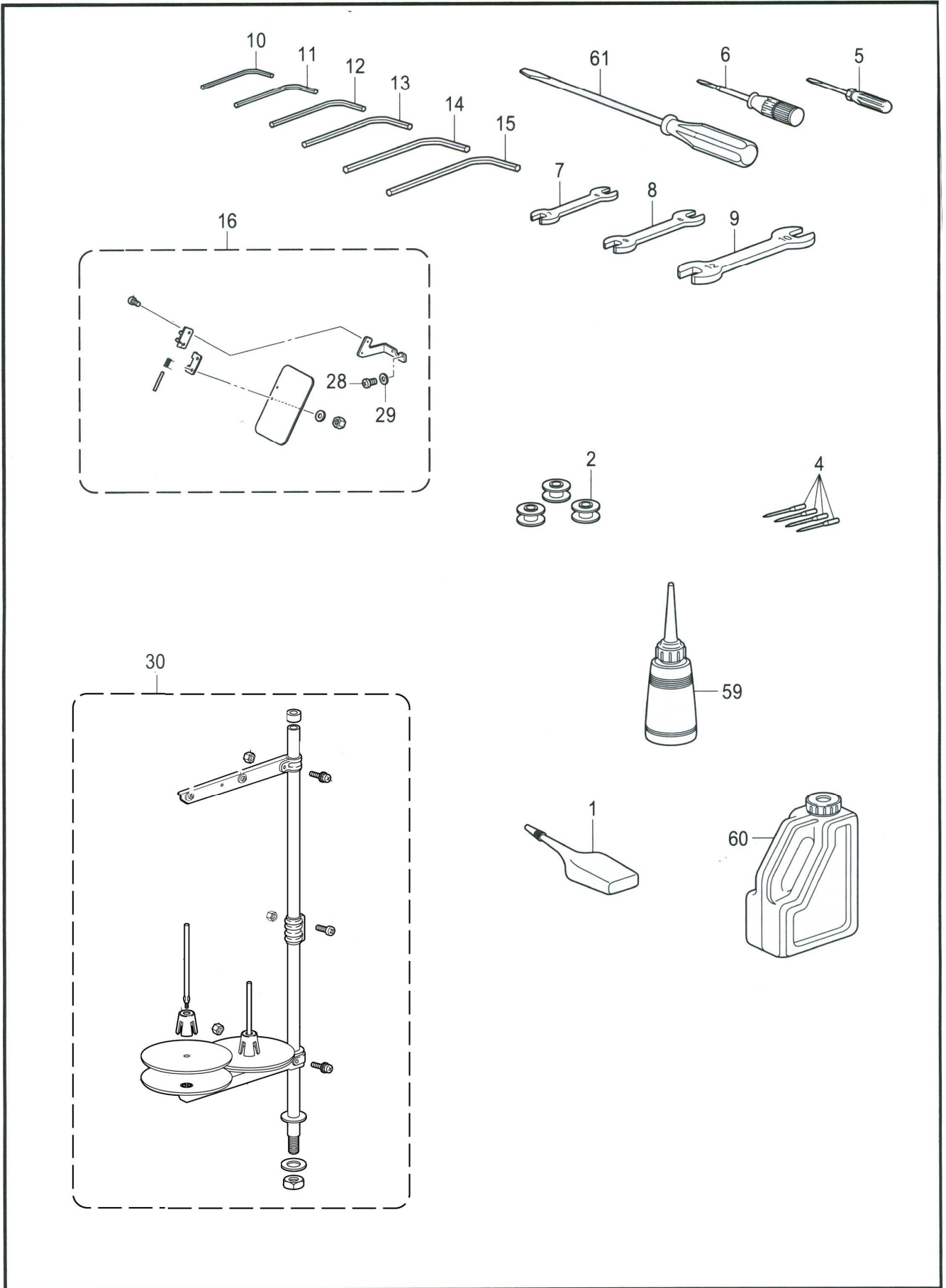

3020>Z. 附件/Accessories						
序号	ERP编号	零部件序号	数量	名称	NAME OF PARTS	备注
Z-01	SCJ6021	S06706001	1	硅油	SILICONE OIL	
Z-02	PF1310E39	S44633001	3	梭芯	BOBBIN LAN	
Z-03	PFDTDP1719	SA1645019	1	机针组145646	NEEDLE 4PIECE ASSY ,145646	
Z-04	PFDTDP1719	145646019	4	机针DPX17	NEEDLE ,DPX17	
Z-05	PF55501018	142443001	1	小起子1.9X52	SCREW - DRIVER ,1.9X52	
Z-06	PF55501017	118837001	1	起子3.4X70	SCREW - DRIVER ,3.4X70	
Z-07	PF1310R20	107779001	1	扳手6X7	WRENCH ,6X7	
Z-08	PF7811937	100887001	1	双头扳手8X9	WRENCH ,8X9	
Z-09	PF1310R22	107780001	1	扳手10X12	WRENCH ,10X12	
Z-10	SCJ6001	S07783001	1	内六角扳手1.5	HEXAGONAL WRENCH ,1.5	
Z-11	SCJ6002	142002001	1	内六角扳手2	HEXAGONAL WRENCH ,2	
Z-12	SCJ6003	154125001	1	1内六角扳手2.5	HEXAGONAL WRENCH ,2.5	
Z-13	SCJ6004	142721001	1	内六角扳手3	HEXAGONAL WRENCH ,3	
Z-14	SCJ6005	118064001	1	内六角扳手4	HEXAGONAL WRENCH ,4	
Z-15	SCJ6006	150335001	1	内六角扳手5	HEXAGONAL WRENCH ,5	
Z-16	PF1310R88	SA4103001	1	护眼板组件	EYE GUARD SETD	
Z-28	PF1310D106	062400616	2	螺钉M4X6	SCREW PAN M4X6	
Z-29	SCJ3010	026040136	2	平垫圈S4	WASHER PLAIN S4	
Z-30	PF55501127	S40574309	1	线架组件2	COTTON STAND ASSY 2DTHF	
Z-59	PF68425Z134	114483002	1	油壶组件	OILER ASSY	
Z-60	PF55501022	S55663001	1	油罐组件	OIL TANK ASSY	
Z-61	PF55501016	101572102	1	起子5.5X190	SCREW - DRIVER 5.5X190	